



## **Welcome to Bluebonnet Electric Cooperative**

Bluebonnet Electric Cooperative Inc. was incorporated in 1939 as the Lower Colorado River Electric Cooperative. The name of the Cooperative was changed to Bluebonnet Electric Cooperative, Inc. in 1964, to enhance a separate identity from the Lower Colorado River Authority (LCRA).

Bluebonnet serves all or part of 14 counties, covers over 3,800 square miles and serves more than 120,000 meters. Bluebonnet operates five retail centers: Bastrop, Brenham, Lockhart, Giddings and Manor. Bluebonnet is one of the largest electric cooperatives in Texas. A distribution cooperative, Bluebonnet purchases most of its power wholesale from the LCRA. Bluebonnet operates and maintains approximately 12,000 miles of distribution lines. Bluebonnet owns 26 substations and purchases power at 22 additional substations owned by the LCRA.

Bluebonnet provides this packet to all developers and their agents and it should be used as a guide in planning the installation of electrical equipment for receiving electrical power from the distribution system of Bluebonnet.

The information presented is subject to change and will be revised periodically to reflect any changes which may develop. Please refer to our website at [bluebonnet.coop](http://bluebonnet.coop) for any additional information as well as an online source of this packet.

Thank you. We look forward to working with you as your electrical provider.

Bluebonnet Project Coordination Staff



# Bluebonnet Electric Cooperative, Inc. Detailed Commercial Load Data

Bluebonnet Electric Cooperative, Inc.  
Attn: Engineering Department  
3198 E. Austin Street  
Giddings, TX 78942  
Phone: (800) 842-7708

**BBEC Internal Usage Only**

Customer # \_\_\_\_\_

W.O. # \_\_\_\_\_

Email Address: \_\_\_\_\_

Applicant Name: \_\_\_\_\_

Phone No: \_\_\_\_\_

Service Address: \_\_\_\_\_

Date: \_\_\_\_\_

**REQUESTED ELECTRICAL SERVICE**    Service/Project Name: \_\_\_\_\_

**PRIMARY SERVICE**

- Overhead
- Underground

**SECONDARY SERVICE**

- Overhead
- Underground

**REQUESTED VOLTAGE**

120/240 - 1Ø 3 Wire

240/480 - 1Ø 3 Wire

- Single-phase transformers are limited to (1) 100 kVA transformer per overhead service & (1) 167 kVA pad mount transformer per underground service.

208/120 - 3Ø 4 Wire Wye

480/277 - 3Ø 4 Wire Wye

240/120 - 3Ø 4 WIRE DELTA (O/H banks only)

- Three-phase transformers are limited to (3) 100 kVA transformer per overhead service

Primary Voltage 12.47/7.2kV or 24.9/14.4kV

**MAIN DISCONNECT** (AMPERES) New \_\_\_\_\_ Existing (If Any) \_\_\_\_\_

Total connected load in Amps (Should Match Page 2 Total). \_\_\_\_\_

**SECONDARY SERVICE ENTRANCE CONDUCTORS**

Copper Wire       Aluminum Wire

Wire Size \_\_\_\_\_ Quantity \_\_\_\_\_ per phase    Quantity \_\_\_\_\_ for the neutral

- Each Phase MUST be sized to accommodate the TOTAL DISCONNECT SIZE or FUSE/BREAKER installed.
- Commercial service MUST pull in a full size neutral whether it will be used or not.

**SECONDARY SERVICE ENTRANCE CONDUIT**

Size of Conduit \_\_\_\_\_ in.      Quantity of Conduit \_\_\_\_\_



**Building Size:** \_\_\_\_\_ SQ.FT.

**Hours of operation:** \_\_\_\_\_ **Days of the week:** \_\_\_\_\_

**Motors** (Other Than Air Conditioning)

- Motors or motor loads totaling more than 25 HP, may require soft starters or VFD's(Variable Frequency Drives) and/or 3 Phase Service. VFD's will require appropriate filtering. Please Contact Bluebonnet Electric's Engineering Department for further information.

1Ø  3Ø  \_\_\_\_\_ HP \_\_\_\_\_ Quantity \_\_\_\_\_ (Amps)

1Ø  3Ø  \_\_\_\_\_ HP \_\_\_\_\_ Quantity \_\_\_\_\_ (Amps)

1Ø  3Ø  \_\_\_\_\_ HP \_\_\_\_\_ Quantity \_\_\_\_\_ (Amps)

1Ø  3Ø  \_\_\_\_\_ HP \_\_\_\_\_ Quantity \_\_\_\_\_ (Amps)

1Ø  3Ø  \_\_\_\_\_ HP \_\_\_\_\_ Quantity \_\_\_\_\_ (Amps)

**Total Motor** \_\_\_\_\_ **HP** \_\_\_\_\_ **(Amps)**

**Total Load on System**

Heating Load \_\_\_\_\_ (Amps) \_\_\_\_\_ (kW)

A/C Load \_\_\_\_\_ (Amps) \_\_\_\_\_ (kW)

Lighting Load \_\_\_\_\_ (Amps) \_\_\_\_\_ (kW)

Motor Load \_\_\_\_\_ (Amps) \_\_\_\_\_ (kW)

Other Load \_\_\_\_\_ (Amps) \_\_\_\_\_ (kW)

**Total Load** \_\_\_\_\_ **(Amps)** \_\_\_\_\_ **(kW)**

LICENSED ELECTRICIAN/ENGINEER SIGNATURE: \_\_\_\_\_

PRINT NAME: \_\_\_\_\_ LICENSE # \_\_\_\_\_

DATE: \_\_\_\_\_ PHONE # \_\_\_\_\_

## Developer's Checklist

### **Responsibility of Developer:**

- Developer must fill out a Development Information Request Form and submit to Bluebonnet along with design fee if required.
- Developer is responsible for confirming all Bluebonnet easement requirements with Bluebonnet prior to platting.
- Developer must have an engineering firm submit preliminary plan of development in digital (AutoCAD) format to Bluebonnet Engineering Department. These plans must include streets, wet utilities, and grading plans as well as any other utilities planned for said development. BBEC will not accept removable media devices for file submissions. For files that are too large to send via email, a BBEC FTP Site will be provided.
- A design/re-design fee of \$50/hr. could be required either prior to or following the design process. This decision will be made at the discretion of Bluebonnet on a case by case basis. These fees are non-refundable and are subject to revision at Bluebonnet's discretion.
- Prior to Bluebonnet construction, two (2) hard copies of the approved plat must be submitted.
- Developer must provide and install all underground conduits at road crossings in the designated locations per Bluebonnet Crossing Plans, and if applicable, all electrical conduits in designated locations per Bluebonnet Construction Plans. See Bluebonnet Specifications. \*\*If project design includes overhead primary lines and transformers in conjunction with underground meter pedestals, Developer may install road crossings ONLY. Bluebonnet contractors shall complete installation from road crossings to point of termination and this labor and material will be figured into the respective Contribution In Aid of Construction (CIAC).\*\*
- Developer is responsible for following Bluebonnet inspection policies and procedures prior to and during conduit installation if using his own contractor (see Page 8).
- Property pins must be set and clearly visible at all property corners, at developer's expense, prior to Bluebonnet commencing construction.
- Developer is responsible for submitting contribution-in-aid of construction (CIAC) to cover Bluebonnet's construction costs prior to Bluebonnet commencing construction. Bluebonnet department will contact developer to communicate planned construction start date and duration following project being released for scheduling.
- Developer is responsible for all right-of-way clearing and grubbing to Bluebonnet specifications. Bluebonnet will clear the right-of-way for proposed overhead facilities for an additional charge. See Bluebonnet Specifications.
- Developer is responsible for ensuring conduit contractor and/or subcontractor adherence to all Bluebonnet Construction Specifications at all times.
- Developer is to provide ALL materials necessary for the conduit system he installs for his Bluebonnet Underground System. Bluebonnet will own these materials after proper installation is certified by a Bluebonnet Inspector.

# **Developer's Fees and Information**

## **Development Fees**

1. A design/re-design fee of \$50/hr. could be required either prior to or following the design process. This decision will be made at the discretion of Bluebonnet on a case by case basis. These fees are non-refundable and are subject to revision at Bluebonnet's discretion.
2. Every request for design and every alteration to all initial requests for design services may be considered as an individual request and, therefore are subject to additional fees to be determined by Bluebonnet.
3. When the developer or prospective developer enters into a line extension agreement with Bluebonnet for service, monies received for engineering design estimates of service will be applied to the cost of construction. Bluebonnet's Line Extension Policy can be found in the enclosed Member Handbook or on the "Residential Development" link on our website at [www.bluebonnetelectric.coop](http://www.bluebonnetelectric.coop)
4. If the developer or prospective developer does not notify Bluebonnet within a 180 day period of initial design with the intent to proceed, then any design fees paid to date will be forfeited and the prospective project will be treated as new.
5. A maintenance fee of \$1 per linear foot of trench will be required at the time of contribution by the developer to cover the cost of any necessary repairs in the first year following the completion of Bluebonnet facilities installation.

## **Additional Notes**

Underground electrical lines in residential developments (including apartment complexes and any commercial service) shall be looped to accommodate the ability to feed from two or more directions so that in the event of an outage the most number of customers can be provided power until the failed line or equipment is restored. Avoid looping back in the same ditch. Never loop back to the same riser pole, sectionalizing cabinet, or switchgear.

Where three-phase is used to provide single-phase service to individual occupants, the load must be balanced between all three phases as equally as possible. This applies whether the single phase services are individually metered or not.

## **Fire Pumps**

Electric service to fire pumps shall be served through a CT-metered service.

## **Easements / Right-of-Way**

1. Bluebonnet shall be granted, at no cost and in writing suitable for recording, all rights-of-way and easements necessary to serve member, overhead or underground for the erection, maintenance, repair, replacement, removal or use of all wires, poles, machinery, fixtures, or equipment needed to supply and deliver electric service to the member.
2. A signed easement granted to Bluebonnet will be required before construction will commence. Once Bluebonnet facilities are installed, the easement will adhere to the facilities, from the installation point with a 15 foot easement on each side of the centerline (30 feet of easement) of overhead facilities and 20 foot easement (10 feet on each side of the centerline), for underground facilities.
3. Only Bluebonnet equipment or material is allowed to be attached to Bluebonnet property, except where said equipment and/or materials is required to provide electrical service and said equipment and/or material has been authorized by Bluebonnet.
4. Please note that Bluebonnet facilities must be installed in easements that are exclusive to Bluebonnet with no other utilities being allowed in these easements except for buried crossings.

### **Location of Facilities**

All overhead or underground distribution lines and equipment will be located in an area that is easily accessible by Bluebonnet vehicles and personnel.

To prioritize safety for first responders and Bluebonnet Electric Cooperative, Inc.'s (BBEC) service men, the main electrical disconnect for each electrical service shall be installed in a readily accessible outdoor location no more than 100 feet from the transformation site. BBEC's Engineering Department must approve the electrical disconnect location before a design estimate will be provided.



EASEMENT

BEC internal use only
MAP REF. # \_\_\_\_\_
W.O. # \_\_\_\_\_
S.L. # \_\_\_\_\_

THE STATE OF TEXAS
COUNTY OF \_\_\_\_\_

The undersigned \_\_\_\_\_ (print name(s) of Owner(s)), ("Grantor"), for a good and valuable consideration, the receipt of which is hereby acknowledged, does hereby grant and convey unto BLUEBONNET ELECTRIC COOPERATIVE, INC. ("Grantee"), whose post office address is P.O. Box 729, Bastrop, Texas 78602, and its legal representatives, successors and assigns, a non-exclusive, permanent and perpetual easement and right of way (the "Easement") in, upon, below or above Grantor's lands, situated in the County of \_\_\_\_\_, State of Texas, and described as follows (the "Property"):

A tract of land consisting of approximately \_\_\_\_\_ acres in the \_\_\_\_\_, or described in a deed or other instrument recorded in Volume/Book \_\_\_\_\_, Page \_\_\_\_\_, or Instrument # \_\_\_\_\_, Real Property Records of \_\_\_\_\_ County, Texas.

The area of the Easement for Overhead Electric Facilities shall be 15 feet on each side of the centerline of the initial line(s) as constructed by Grantee (the "Easement Area"), and the area of the Easement for Underground Electric Facilities shall be 10 feet either side of the initial line(s) as constructed by Grantee (the "Easement Area"). In addition, Grantee shall have the right to install guy and anchor arrangements inside and/or outside the Easement Area when and where Grantee deems necessary; any area in which such guy and anchor arrangements are installed outside the Easement Area as defined above shall, while such items are in place, be included within the definition of the Easement Area.

The purpose and scope of this Easement is to place, construct, re-construct, re-phase, operate, maintain, relocate, replace and remove in, upon, below or above the Easement Area an electric distribution line or system, telecommunications systems and equipment, or other services and systems, and its related appurtenances and equipment, and to cut, trim, chemically treat, and/or remove any or all trees, brush, shrubbery or other obstructions within or outside the Easement Area to the extent necessary to keep the Easement Area clear, or which might otherwise endanger or interfere with the efficiency of the lines, including the removal of any dead, weak, leaning or dangerous trees that are tall enough to strike the wires in falling even if same are located outside the Easement Area. Non-use of the Easement shall not be deemed an abandonment; the Easement shall only be terminated by written instrument executed by Grantee and recorded in the real property records of the county or counties in which the Easement Area is located. The purpose and scope of this Easement may not be changed, and Easement Area may not be relocated, without Grantee's written consent.

Grantee shall have the right of pedestrian, vehicular, and equipment ingress and egress over the Property, or any other of Grantor's adjacent lands, to and from the Easement Area for the purpose of placing, constructing, re-constructing, re-phasing, operating, maintaining, relocating, replacing and removing said lines and appurtenances, and may make use of such Property or other lands outside the Easement Area as is reasonably necessary for such activities, including the temporary placement and storage of vehicles and equipment.

To have and to hold unto Grantee, its legal representatives, successors and assigns, forever. Grantor binds Grantor and Grantor's heirs, executors, administrators, legal representatives, successors and assigns to warrant and forever defend all and singular the rights herein to Grantee, its legal representatives, successors and assigns against every person whomsoever lawfully claiming or to claim the same or any part thereof. This is an easement appurtenant and is a covenant running with the land.

Grantor may not construct or place any structures, devices, or obstacles in or on the Easement Area that may in Grantee's opinion constitute a hazard to the safe and reliable operation of the lines and appurtenances installed in the Easement Area or in the opinion of Grantee, a danger to Grantor or the general public.

Grantor warrants that Grantor is the legal owner of the Property and the undersigned has authority to grant this Easement and that the Property is free and clear of encumbrances and liens of whatsoever character except those held by the following:

Grantor authorizes any employee, agent or other representative of Grantee to complete any blank spaces pertaining to the Property description above after this Easement has been executed by Grantor.

This written Easement represents the only agreement pertaining to said Easement.

The undersigned has executed this Easement to be effective as of the \_\_\_\_\_ day of \_\_\_\_\_, 20\_\_\_\_.

\_\_\_\_\_  
(Grantor's Printed Name)

\_\_\_\_\_  
(Signature of Grantor or Grantor's Authorized Representative)

\_\_\_\_\_  
(Grantor's Printed Name)

\_\_\_\_\_  
(Signature of Grantor or Grantor's Authorized Representative)

STATE OF TEXAS                    §  
   §  
COUNTY OF \_\_\_\_\_       §

This instrument was acknowledged before me on \_\_\_\_\_, 20\_\_\_\_ by \_\_\_\_\_.  
(Grantor's Printed Name)

\_\_\_\_\_  
Notary Public, State Of Texas

STATE OF TEXAS                    §  
   §  
COUNTY OF \_\_\_\_\_       §

This instrument was acknowledged before me on \_\_\_\_\_, 20\_\_\_\_ by \_\_\_\_\_.  
(Grantor's Printed Name)

\_\_\_\_\_  
Notary Public, State Of Texas

After recording, please return to:  
Bluebonnet Electric Cooperative, Inc.  
3198 East Austin Street  
Giddings, Texas 78942

## Developer Installed Conduit Guidelines and Procedures

1. Developer will review Bluebonnet's construction specifications prior to trenching and conduit installation (specifications included in this document). Developer is encouraged to contact Bluebonnet inspector listed in #3 below with any questions.
2. Developer must provide and install all underground material in the designated locations per Bluebonnet's design. Bluebonnet will provide and install the associated hardware such as sectionalizers and transformers that will be located above ground.
3. Developer will contact the Bluebonnet Project Coordinator when conduit and stub-ups are installed prior to filling the ditch (open ditch inspection). Bluebonnet will respond within 48 hours of notification. Please choose from the list of Bluebonnet Project Coordinators to schedule an inspection.
  - **Project Coordinator Rodney Gerik, may be reached at (979) 540-8814 (cell), or at [Rodney.gerik@bluebonnet.coop](mailto:Rodney.gerik@bluebonnet.coop).**
  - **Project Coordinator Shawn Ely, may be reached at (979) 540-7361 (cell), or at [Shawn.ely@bluebonnet.coop](mailto:Shawn.ely@bluebonnet.coop).**
  - **Project Coordinator Camryn Nutt, may be reached at (512) 718-2929 (cell), or at [Camryn.nutt@bluebonnet.coop](mailto:Camryn.nutt@bluebonnet.coop)**
  - **Project Coordinator Shane Mathison, may be reached at (979) 542-8540, or at [Shane.mathison@bluebonnet.coop](mailto:Shane.mathison@bluebonnet.coop).**
  - **Project Coordinator Jorge Varillas, may be reached at (512) 764-2838, or at [Jorge.Varillas@bluebonnet.coop](mailto:Jorge.Varillas@bluebonnet.coop).**
  - **Project Coordinator Scott Iselt, may be reached at (979) 542-8522, or at [Scott.Iselt@bluebonnet.coop](mailto:Scott.Iselt@bluebonnet.coop).**
  - **Project Coordinator Wyatt Rosenauer, may be reached at (512) 332-8665, or at [Wyatt.Rosenauer@bluebonnet.coop](mailto:Wyatt.Rosenauer@bluebonnet.coop).**
4. Trenches will remain open until inspected and approved by the Bluebonnet inspector. Upon inspection, developer will be advised as to what may or may not be backfilled.
5. Bluebonnet retains the right to terminate any conduit installation if inspection reveals non-compliance with Bluebonnet inspection policies, procedures, or specifications until said issues are resolved and approved through re-inspection.
5. Equipment location and conduit stubs must meet clearance requirements on all sides as outlined in Bluebonnet Specifications.
6. Developer or his/her contractor is responsible for acquiring any and all permits and remitting any necessary fees for trench and conduit installation (excavation plans, traffic control plans, digging permits, etc.)

## **Developer's Checklist**

### **Responsibility of Developer:**

- Developer is responsible for confirming all easement requirements with Bluebonnet prior to installation.
- Developer is responsible for following Bluebonnet's inspection policies and procedures prior to and during conduit installation.
- Developer is responsible for all right-of-way clearing or grubbing to Bluebonnet's specifications.
- Developer is responsible for adherence to all Bluebonnet's Construction Specifications.

## **Developer's Fees and Information**

1. Every request for alteration to initial requests for design services are subject to additional fees to be determined by Bluebonnet.
2. Bluebonnet's Line Extension Policy can be found in the Member Handbook.
3. A maintenance fee of \$1 per linear foot of trench will be required at the time of contribution by the member to cover the cost of any necessary repairs in the first year following the completion of Bluebonnet's underground facilities installation.
4. Cost estimate given to developer will be good for **60** days.

## Bluebonnet Large Power Rate Overview

Rate	Wholesale Charge	Distribution Charge	Demand Charge & Minimum*	Service Availability Charge	Description
Single Phase	\$0.058936 per kWh	\$0.037214 per kWh	n/a	\$30.00 per month	Available to all commercial, industrial and other consumers whole electric requirements for all uses less than 50 kW.
Three Phase	\$0.058936 per kWh	\$0.039114 per kWh	n/a	\$50.00 per month	Available to all commercial, industrial and other consumers whole electric requirements for all uses less than 50 kW.
Large Power	\$0.058936 per kWh	\$0.015091 per kWh	50 kW minimum at \$5.00 per kW	\$75.00 per month	Available to all commercial and industrial consumers whole electric requirements for all uses are 50 kW to 250 kW.
Large Power > 250 kW	\$0.058936 per kWh	\$0.009578 per kWh	250 kW minimum at \$6.00 per kW	\$150.00 per month	Available to all commercial and industrial consumers whole electric requirements for all uses are greater than 250 kW.
Key Account	\$0.058936 per kWh	\$0.000000 per kWh	1,000 kW minimum at \$6.50 per kW \$4.88 per kW for excess of 5,000 kW	\$600.00 per month	Available to all commercial and industrial consumers whose electric requirements for all uses are greater than 1,000 kW.

\*The demand shall be the maximum kilowatt (kW) demand established by a Member for any thirty (30) minute interval during the billing month but not less than the minimum kW required within the specified rate.



**Bluebonnet**

MEMBER RESPONSIBILITY

BLUEBONNET RESPONSIBILITY

<p>Deliver essential project documents to Bluebonnet Electric Coop. Site plan files (CAD Format), load information, information request form(s), project schedule, and electrical one line document(s).</p>	<p><b>BEFORE THE CLOCK STARTS</b></p>	<p>Facilitate correspondence with member/developer to discuss needs and review available information.</p>
<p>Host a site visit and/or Pre-design Meeting/Call with Bluebonnet Representative(s). Provide up to date and accurate Project Schedule for all stages, including desired energization date.</p>		<p>Provide Bluebonnet Developer's Package (Commercial/Residential); including standard Bluebonnet Easement.</p>
		<p>Collect information from Member/Developer.</p>
<p><b>**Bluebonnet Electric cannot begin design of project until all required documentation is received.**</b></p>		<p>Verify a complete member package has been received, including all required documentation.</p>
<p>Expedite payment to Bluebonnet Electric for project. Provide any required third party easements and outstanding information.</p>	<p><b>WEEK #1</b></p>	<p>Attend site visit or Pre-design meeting, evaluate site layout, utility coordination, member construction coordination, jobsite construction access, etc.</p>
	<p><b>WEEKS #2-#5</b></p>	<p>Design electric service layout; coordinate with the electric system (circuit capacity, fuses). Size equipment, determine rate class for Community Representative to communicate to Member.</p>
<p><b>**Bluebonnet Electric will not release project for scheduling (apartments and subdivisions) until addressing information is received.**</b></p>	<p><b>WEEKS #6-#7</b></p>	<p>Prepare and submit any necessary permits. Schedule and complete field staking of project. Finalize and secure all easements.</p>
	<p><b>WEEK #8</b></p>	<p>Create cost estimate and deposit and send cost letter and Site Ready Letter to developer.</p>
<p><b>**Bluebonnet Electric cannot begin construction of project until Site Ready documentation is received.**</b></p>	<p><b>WEEK #9</b></p>	
	<p><b>WEEKS #10-#11</b></p>	<p>Process project payment.</p>
<p>Construction crews will leave the site if suitable construction conditions are unsatisfactory.</p>	<p><b>WEEK #12</b></p>	<p>Prepare for and release project to construction. Verify material availability and receipt of developer's Site Ready Letter.</p>
	<p><b>WEEKS #13-#28</b></p>	<p>Upon release, Construction Lead (Contract Coordinator or Bluebonnet Construction) will contact member within two business days to provide anticipated construction start date, duration, planned completion, etc.</p>
<p>Member completes preparation for final electric service delivery.</p>		<p>Request crew scheduling from construction. Complete inspections and accept installations. Verify site is prepared and ready for construction.</p>
		<p>Construct Bluebonnet Electric Facilities.</p>
	<p><b>WEEKS #29-#30</b></p>	<p>Inspect final installation. Energize project and initiate electric service.</p>
<p>Member requests initiation of final electric service.</p>		

- A. If a Member step is late, the project clock **STOPS**. Members/Developers are highly encouraged to stay on top of payments, required easements, and all crucial deliverables and documentation.
- B. Elapsed times are not a guarantee. More than thirty weeks may be needed for larger scope projects or projects that require significant upgrades to Bluebonnet Electric's system infrastructure.
- C. Member/Developer is required to provide Bluebonnet Electric with any and all required easements, including third party, prior to commencing construction.
- D. Bluebonnet Engineering staff are responsible for all steps from project inception through Week #12. Weeks #13 - #30 are managed by Bluebonnet Construction Staff and are denoted in **BLUE**.
- E. Permitting schedule is contingent on regulatory agency approval (response times vary).
- F. Member/Developer is required to notify construction once site is ready by returning a signed Site Ready Letter. **Projects will not be released for scheduling until this document has been returned.**

During the **planning, engineering, and design phase** of your project your main point of contact will be one of Bluebonnet's Project Coordinators. If the Project Coordinator for your project is not available, one of the other team members will be glad to assist you.

**Shawn Ely**  
shawn.ely@bluebonnet.coop  
Office: (979) 542-8518  
Cell: (979) 540-7361

**Scott Iselt**  
scott.iselt@bluebonnet.coop  
Office: (979) 542-8522  
Cell: (979) 540-0195

**Camryn Nutt**  
camryn.nutt@bluebonnet.coop  
Cell: (512) 718-2929

**Rodney Gerik**  
rodney.gerik@bluebonnet.coop  
Office: (979) 542-8527  
Cell: (979) 540-8814

**Shane Mathison**  
shane.mathison@bluebonnet.coop  
Office: (979) 542-8540  
Cell: (512) 577-6817

**Jorge Varillas**  
jorge.varillas@bluebonnet.coop  
Office: (512) 764-2838  
Cell: (512) 376-8291

**Clemente Verastegui**  
clemente.verastegui@bluebonnet.coop  
Office: (979) 542-8542  
Cell: (512) 578-6393

**Thomas Ellis (Manager)**  
thomas.ellis@bluebonnet.coop  
Office: (979) 542-8545  
Cell: (979) 540-6146

**Wyatt Rosenauer**  
wyatt.rosenauer@bluebonnet.coop  
Office: (979) 542-8665  
Cell: (512) 629-5924

During the **construction, inspection, and metering phase** of your project your main point of contact will be Bluebonnet's Contractor Coordinator OR Assistant Superintendent. Bluebonnet's personnel cover specific areas of the service territory; areas are listed with their contact information.

**Joey Tobola (Contractors)**  
joey.tobola@bluebonnet.coop  
Cell: (979) 540-7162

**Randall Bownds (Giddings Area)**  
randall.bownds@bluebonnet.coop  
Office: (979) 542-8516  
Cell: (979) 540-6418

**Chad Lewis (Brenham Area)**  
chad.lewis@bluebonnet.coop  
Office: (979) 277-8558  
Cell: (979) 277-4041

**Aaron Seeliger (Red Rock Area)**  
aaron.seeliger@bluebonnet.coop  
Office: (512) 764-2788  
Cell: (512) 227-2281

**Kenneth Roush (Underground – All Areas)**  
kenneth.roush@bluebonnet.coop  
Cell: (512) 468-5088

**Tim Mittasch (Underground- All Areas)**  
tim.mittasch@bluebonnet.coop  
Cell: (979) 540-7159

**Daniel Fritsche (Bastrop Area)**  
daniel.fritsche@bluebonnet.coop  
Office: (979) 542-8514  
Cell: (979) 542-8546

**Carl Miller (Underground Inspector)**  
carl.miller@bluebonnet.coop  
Cell: (979) 540-6495

**Joe Hernandez (Underground Inspector)**  
jose.hernandez@bluebonnet.coop  
Cell: (720) 670-7299

**Jose Villarreal (Underground Inspector)**  
jose.villarreal@bluebonnet.coop  
Cell: (512) 988-1885

**Martin Dorantes (Underground Inspector)**  
martin.dorantes@bluebonnet.coop  
Cell: (512) 748-4453

**Material Standards:**



**Underground warning tape must be 6” width, RED in color with BLACK lettering, and read “Caution Buried Electric Underground”. \*Normally, this material is only sold in 1000’ rolls.\***

# DITCH AND CONDUIT PLACEMENT NON-ROAD CROSSING

DITCH ASSIGNMENT  
FRONT VIEW

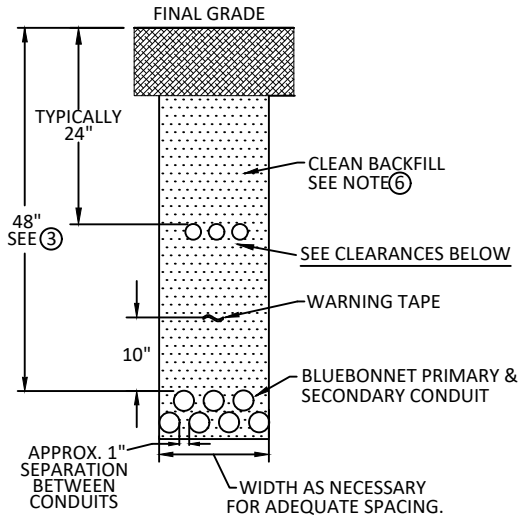

CONDUIT STUB-UP  
SIDE VIEW

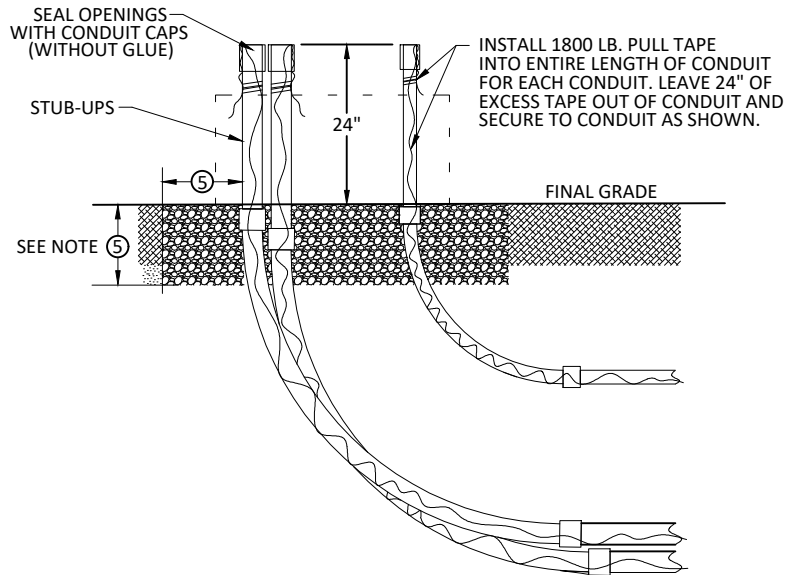

CONDUIT CLEARANCES  
FRONT VIEW

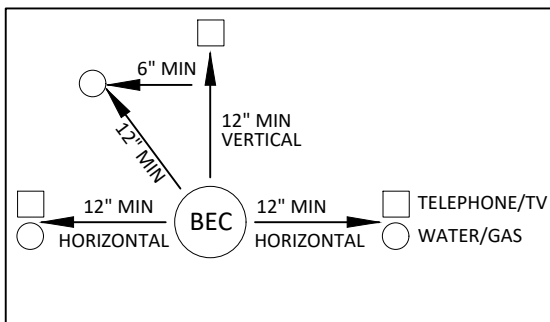

CONDUIT STUB-UP CLEARANCES  
TOP VIEW

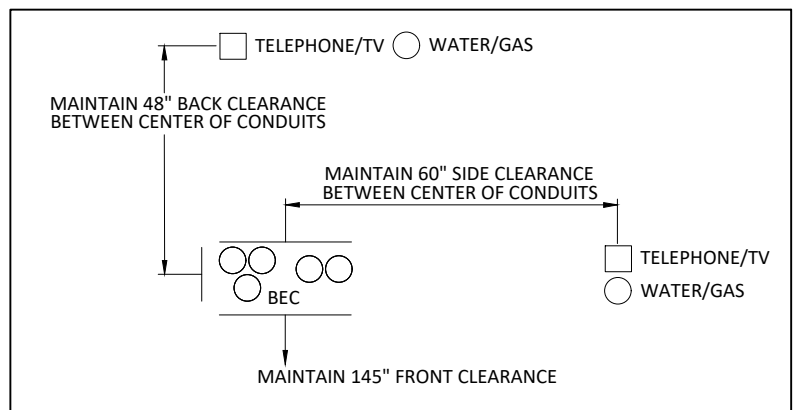

ANY CONDUITS STUBBED OUT FOR FUTURE USE SHALL EXTEND A MINIMUM OF 5' FROM EQUIPMENT. ENDS SHALL BE MARKED WITH 3" DIAMETER GREY PVC CONDUIT, EXTENDING 4' ABOVE GRADE AND PAINTED RED.

- NOTES:**
1. CONDUIT SHALL BE GREY SCHEDULE 40 PVC. | PRIMARY & SECONDARY= 3" | LIGHTING= 2"
  2. CONDUIT ELBOW: PRIMARY & SECONDARY= 90°, 48" SWEEP | STREETLIGHT = 90°, 24" SWEEP
  3. NORMAL DITCH COVER DEPTH IS 48". ADJUSTMENTS MAY BE MADE TO 48" DEPTH IF NECESSARY UPON BLUEBONNET APPROVAL.
  4. SEPARATION FROM OTHER UTILITIES SHALL BE 12" MINIMUM OR SUFFICIENT TO PREVENT ANY FORESEEN DAMAGE OF EITHER FACILITY TO THE OTHER.
  5. GRAVEL FOR PADS SHALL BE 3/8" WASHED PEA GRAVEL. DEPTH AND WIDTH SHALL BE TO EQUIPMENT SPECIFICATION.
  6. BACKFILL MATERIAL SHALL BE CLEAN AND FREE FROM ALL ORGANIC MATERIAL, UNSTABLE MATERIALS, DEBRIS, LUMPS, OR BROKEN PAVING. NO ROCKS OR STONES SHALL BE GREATER THAN 1" IN ANY BACKFILL. THE BACKFILL MUST PROVIDE AN EVEN SUPPORT FOR CONDUITS. MATERIAL FOR BACKFILL MAY BE MATERIAL RESULTING FROM EXCAVATION, IF SUITABLE IN THE OPINION OF THE BBEC INSPECTOR OR BBEC PROJECT COORDINATOR.



**Bluebonnet**

Drawn:	Approved:	Date:
CV	Project Coordinators	Oct. 31, 2019

**UNDERGROUND DISTRIBUTION**

**J-3**

# DITCH AND CONDUIT PLACEMENT ROAD CROSSING

## CONDUIT FRONT VIEW

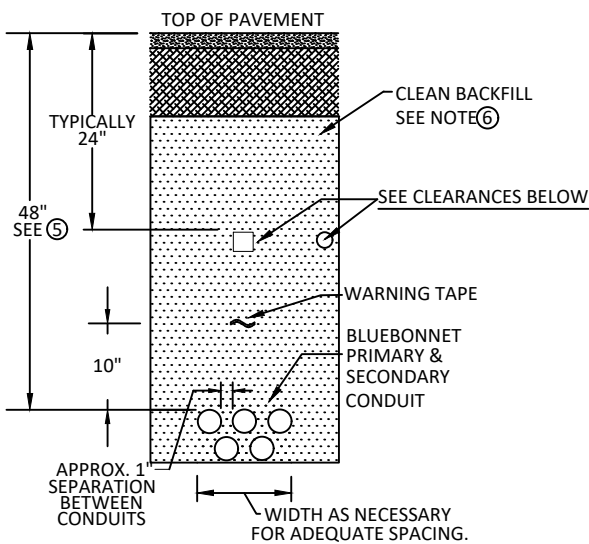

## CONDUIT SIDE VIEW

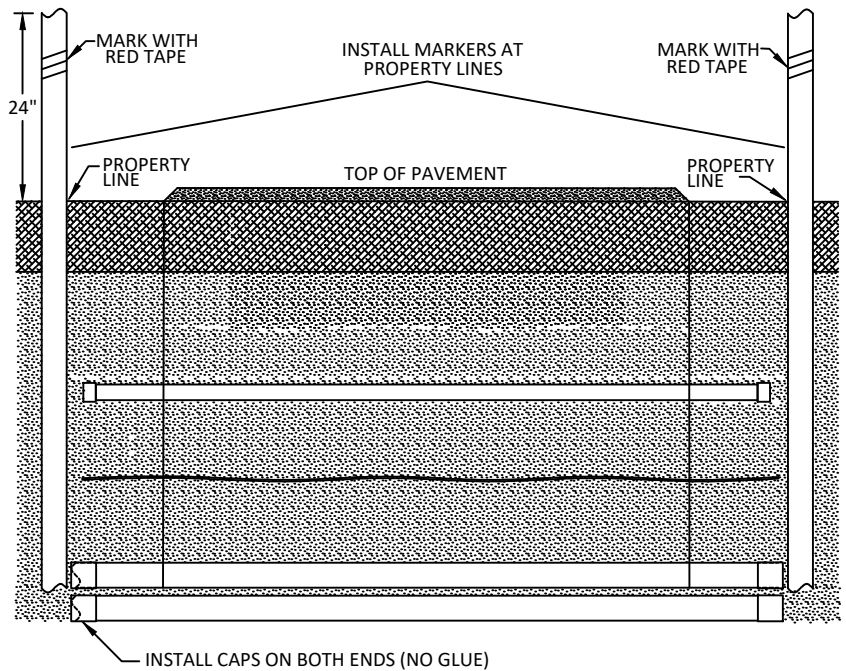

## CONDUIT CLEARANCES FRONT VIEW

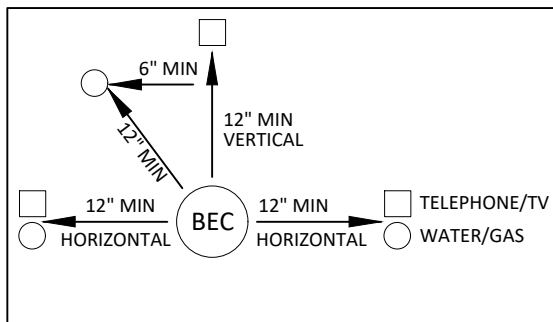

## CONDUIT STUB-UP CLEARANCES TOP VIEW

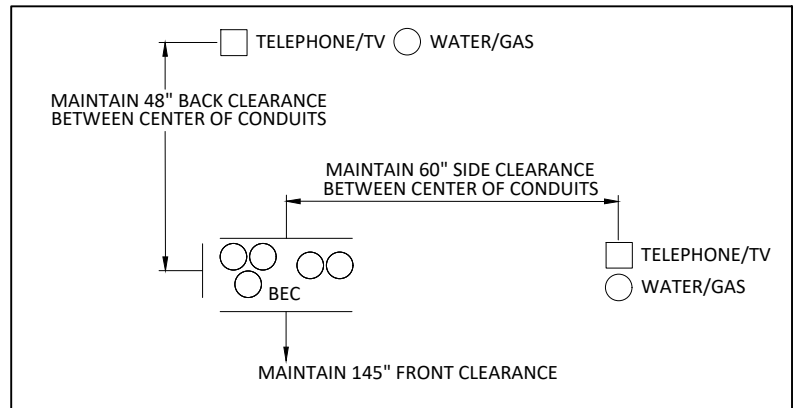

ANY CONDUITS STUBBED OUT FOR FUTURE USE SHALL EXTEND A MINIMUM OF 5' FROM EQUIPMENT. ENDS SHALL BE MARKED WITH 3" DIAMETER GREY PVC CONDUIT, EXTENDING 4' ABOVE GRADE AND PAINTED RED.

**NOTES:**

1. STATE AND LOCAL CODES MAY REQUIRE DIFFERENT STANDARDS, IN WHICH CASE THE MOST STRINGENT CODE SHALL TAKE PRECEDENCE.
2. CONDUIT SHALL BE MINIMUM GRAY SCHEDULE 40 PVC. | PRIMARY & SECONDARY = 3" | LIGHTING = 2"
3. CONDUIT ELBOW: PRIMARY & SECONDARY = 90°, 48" SWEEP | LIGHTING = 90°, 24" SWEEP
4. LENGTH OF CONDUITS SHALL BE FROM PROPERTY LINE TO PROPERTY LINE.
5. NORMAL COVER DEPTH IS 48". ADJUSTMENTS MAY BE MADE TO 48" DEPTH IF NECESSARY UPON BLUEBONNET APPROVAL.
6. BACKFILL MATERIAL SHALL BE CLEAN AND FREE FROM ALL ORGANIC MATERIAL, UNSTABLE MATERIALS, DEBRIS, LUMPS, OR BROKEN PAVING. NO ROCKS OR STONES SHALL BE GREATER THAN 1" IN ANY BACKFILL. THE BACKFILL MUST PROVIDE AN EVEN SUPPORT FOR CONDUITS. MATERIAL FOR BACKFILL MAY BE MATERIAL RESULTING FROM EXCAVATION, IF SUITABLE IN THE OPINION OF THE BBEC INSPECTOR OR BBEC PROJECT COORDINATOR.

Q:\BEC Logo\tiffs\color\bec.logo.horiz.b.tif	Drawn:	Approved:	Date:	<b>UNDERGROUND DISTRIBUTION</b>	<b>J-4</b>
	CV	Project Coordinators	Oct. 31, 2019		

# RISER POLE CONDUIT

## DITCH ASSIGNMENT FRONT VIEW

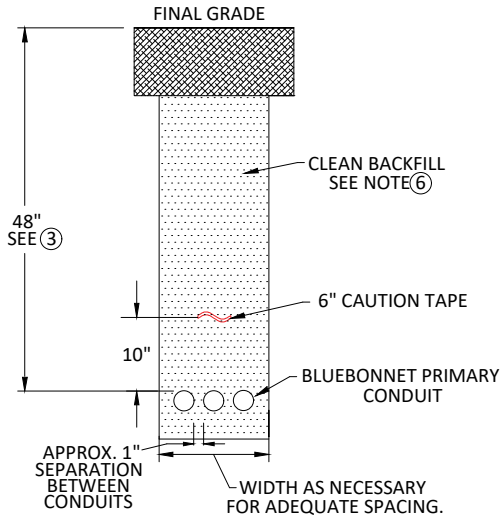

## CONDUIT STUB-UP SIDE VIEW

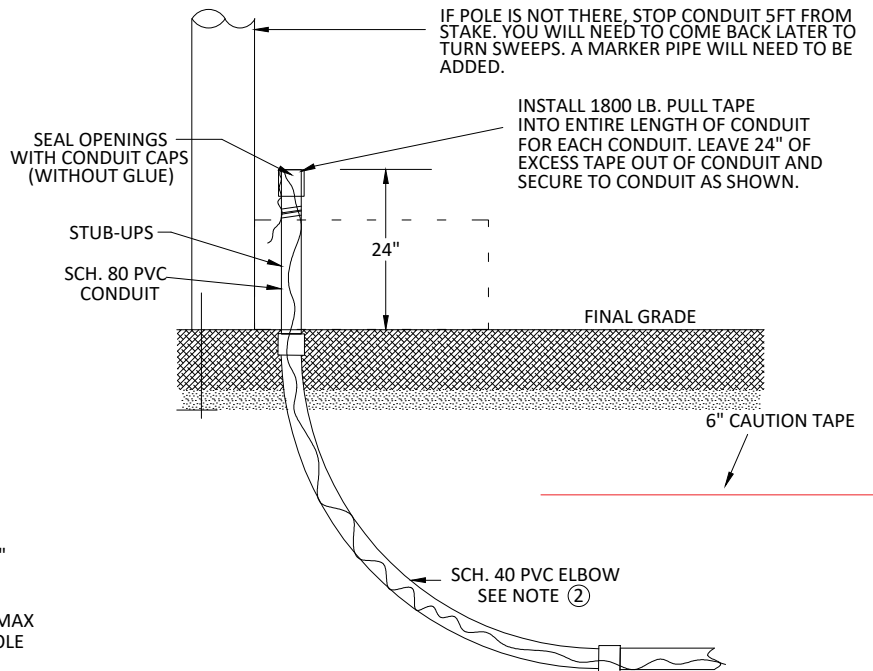

## TOP VIEW

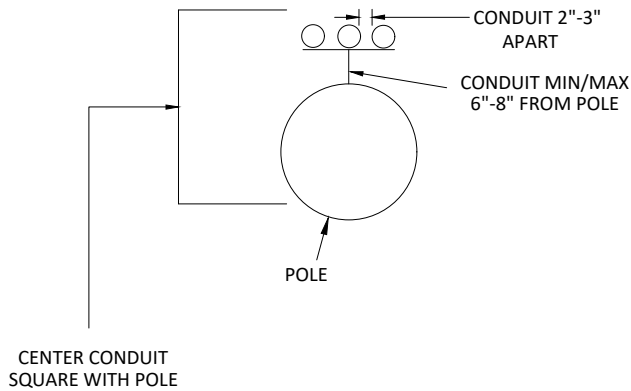

- NOTES:**
1. CONDUIT BELOW GROUND SHALL BE GREY SCHEDULE 40 PVC. | PRIMARY & SECONDARY= 3" | LIGHTING= 2"
  2. CONDUIT ELBOW: PRIMARY & SECONDARY= 90°, 48" SWEEP | STREETLIGHT = 90°, 24" SWEEP
  3. NORMAL DITCH COVER DEPTH IS 48". ADJUSTMENTS MAY BE MADE TO 48" DEPTH IF NECESSARY UPON BLUEBONNET APPROVAL.
  4. SEPARATION FROM OTHER UTILITIES SHALL BE 12" MINIMUM OR SUFFICIENT TO PREVENT ANY FORESEEN DAMAGE OF EITHER FACILITY TO THE OTHER.
  5. BACKFILL MATERIAL SHALL BE CLEAN AND FREE FROM ALL ORGANIC MATERIAL, UNSTABLE MATERIALS, DEBRIS, LUMPS, OR BROKEN PAVING. NO ROCKS OR STONES SHALL BE GREATER THAN 1" IN ANY BACKFILL. THE BACKFILL MUST PROVIDE AN EVEN SUPPORT FOR CONDUITS. MATERIAL FOR BACKFILL MAY BE MATERIAL RESULTING FROM EXCAVATION, IF SUITABLE IN THE OPINION OF THE BBEC INSPECTOR OR BBEC PROJECT COORDINATOR.
  6. CONDUIT ABOVE GROUND SHALL BE GREY SCHEDULE 80 PVC.
  7. FIRST BRACKET WILL BE INSTALLED 24" FROM FINAL GRADE.
  8. ROTATE CONDUIT TO AVOID CONFLICT WITH COMMUNICATION ATTACHMENTS.



**Bluebonnet**

Drawn: JW  
Approved: Standards  
Date: Mar. 26, 2024

**UNDERGROUND DISTRIBUTION**

**J-6**

# 1PH PADMOUNT TRANSFORMER DIMENSIONS AND WIRING

**TOP VIEW**

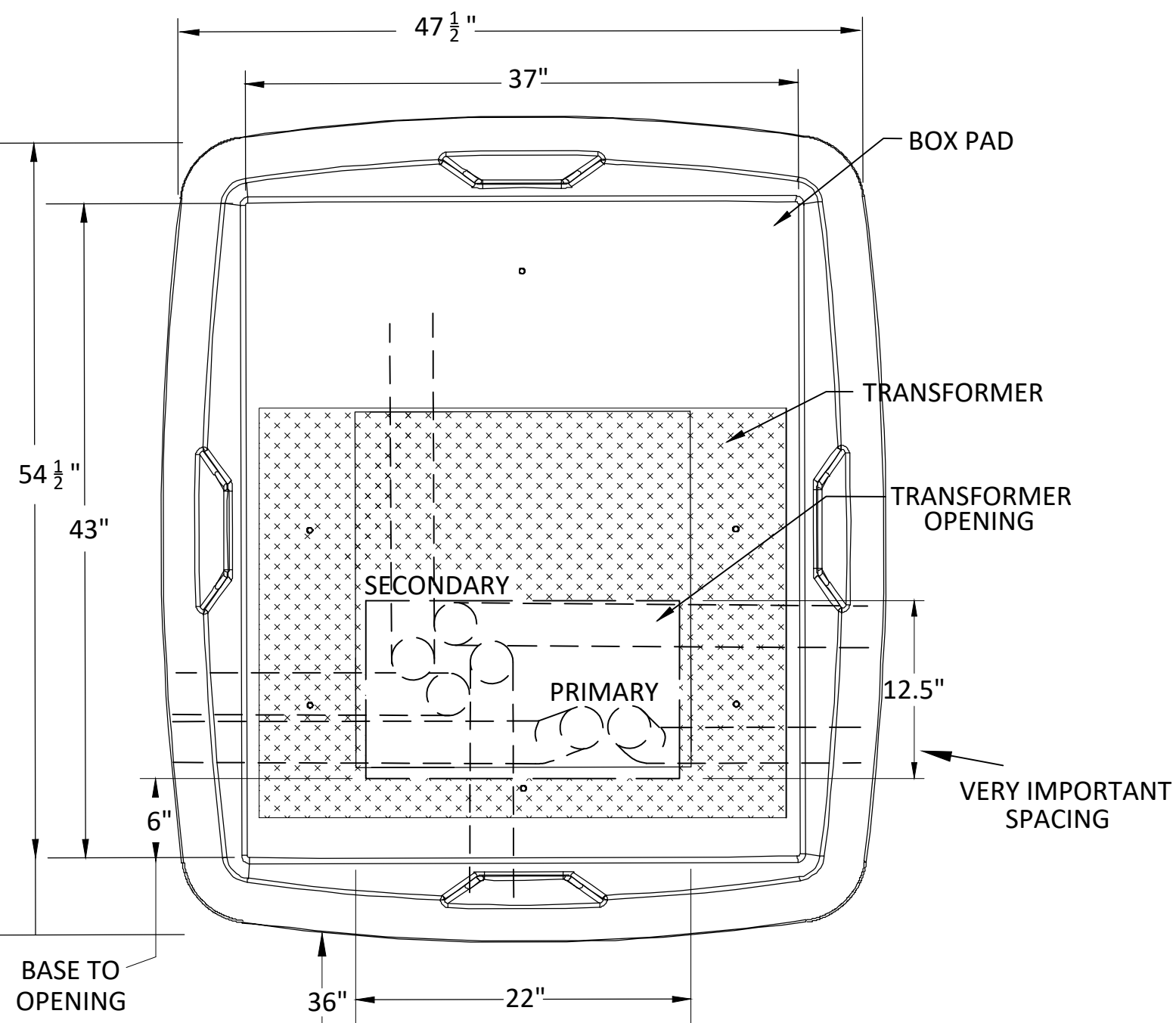

**WIRING DIAGRAM**

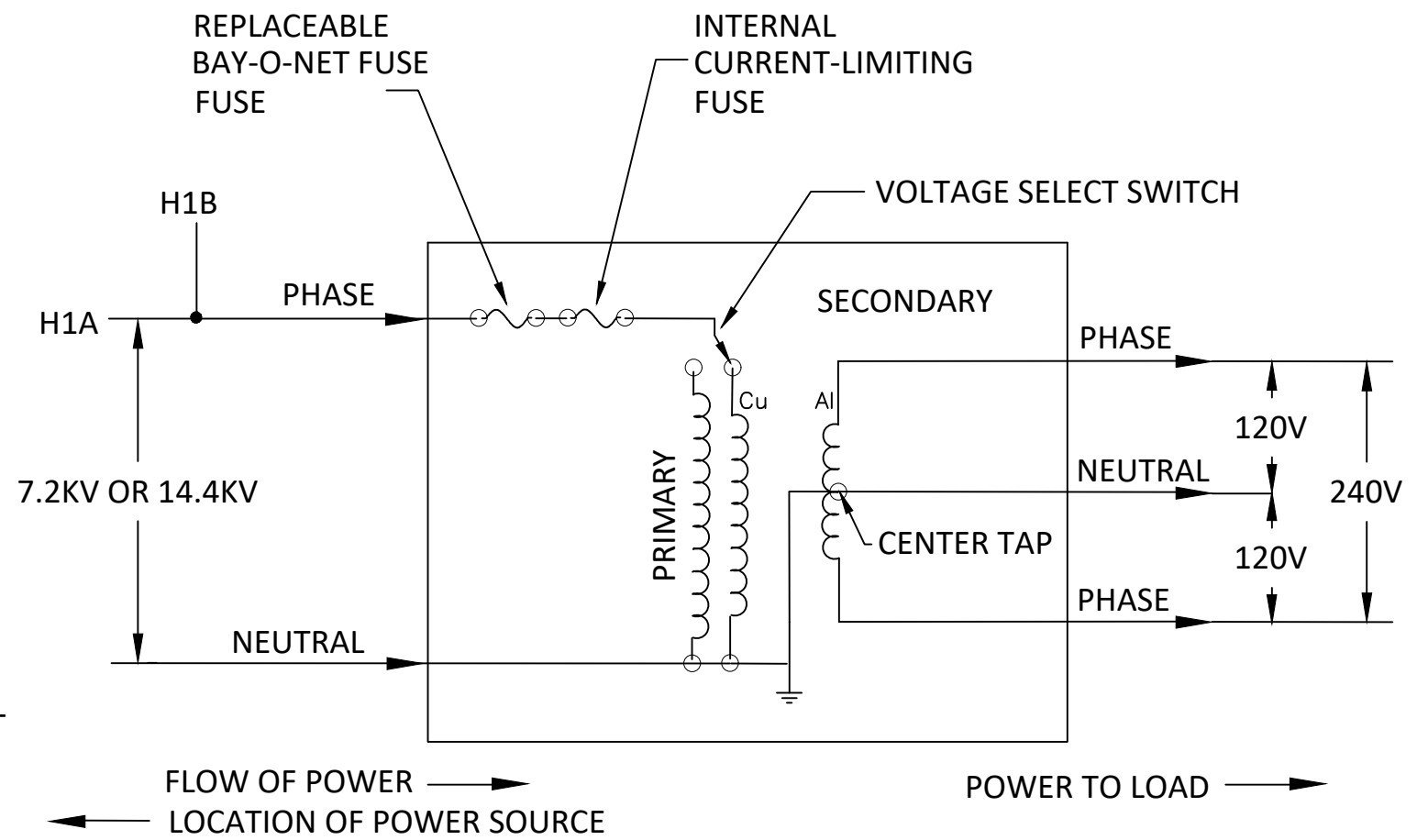

Ⓐ CLEARANCE BETWEEN WALLS AND TRANSFORMER:  
NON-COMBUSTIBLE - 3 FT.  
COMBUSTIBLE: UP TO 75 KVA - 10 FT.  
GREATER THAN 75 KVA - 20 FT.

MEMBER CONDUIT SHALL STOP 36" FROM BOX.  
MEMBER SHALL PROVIDE 2" OR 3" SCH 40 PVC  
CONDUIT ELBOW WITH A 24" SWEEP AND 10' OF  
ADDITIONAL CABLE RUN.  
MAXIMUM ONE CONDUIT PER MEMBER UNLESS  
WRITTEN APPROVAL BY BLUEBONNET PERSONNEL.

**FRONT VIEW**

**SIDE VIEW**

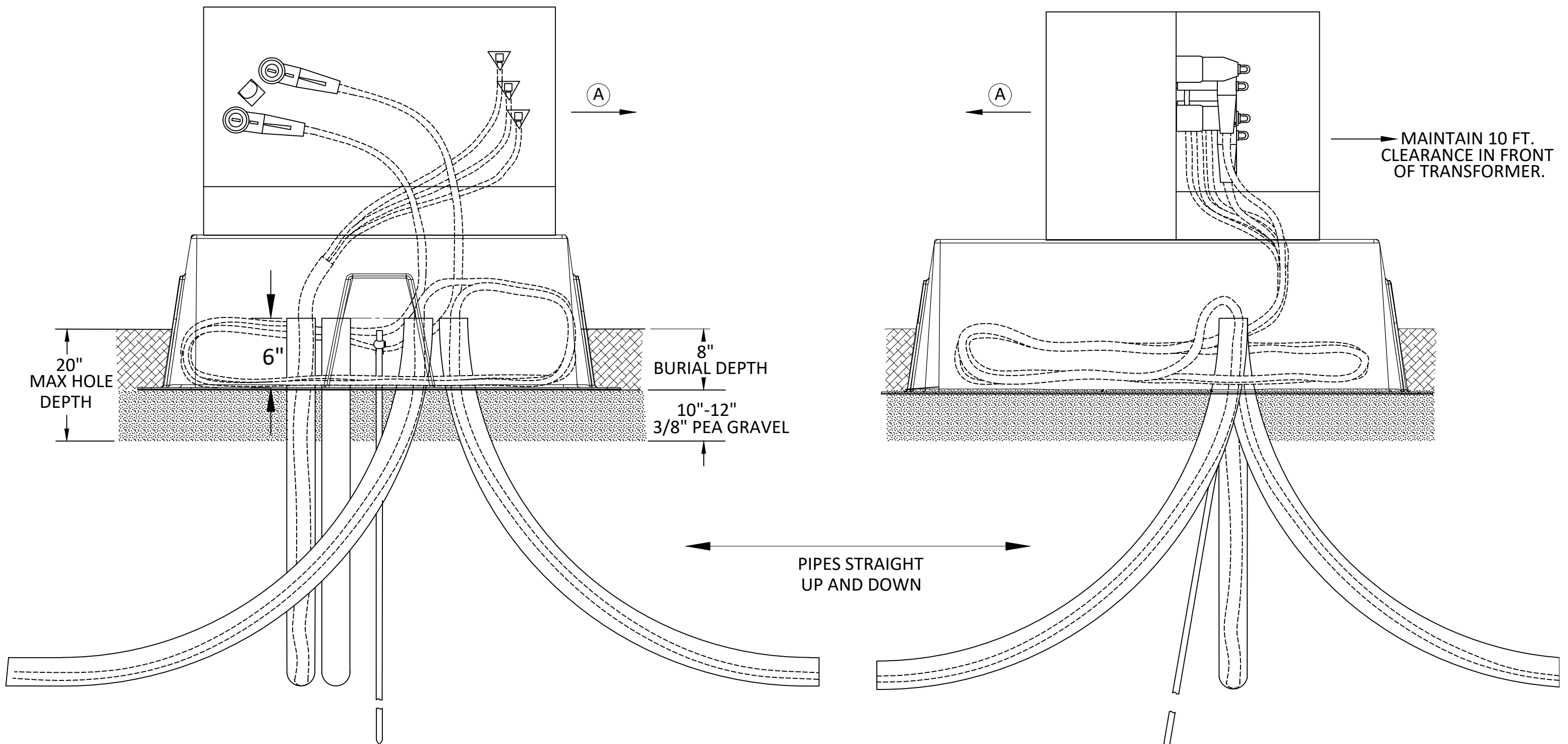

SECONDARY CABLE SIZE SHALL BE MAX 350 AWG.

# 1PH PADMOUNT SECTIONALIZER

## DIMENSIONS AND WIRING

TOP VIEW

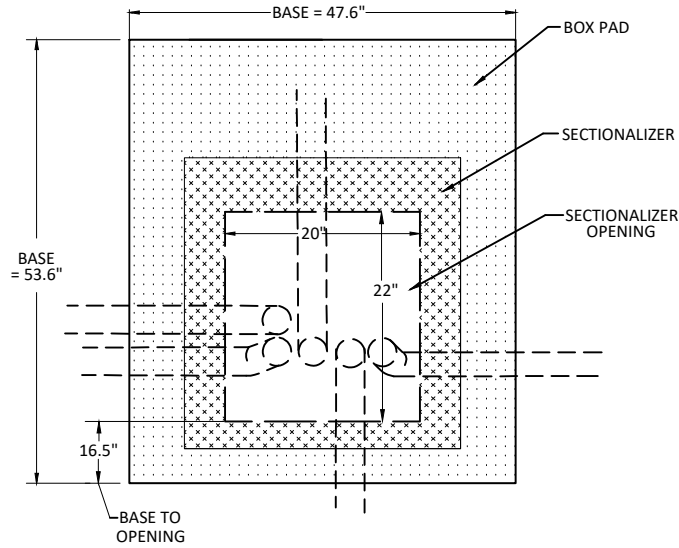

SIDE VIEW

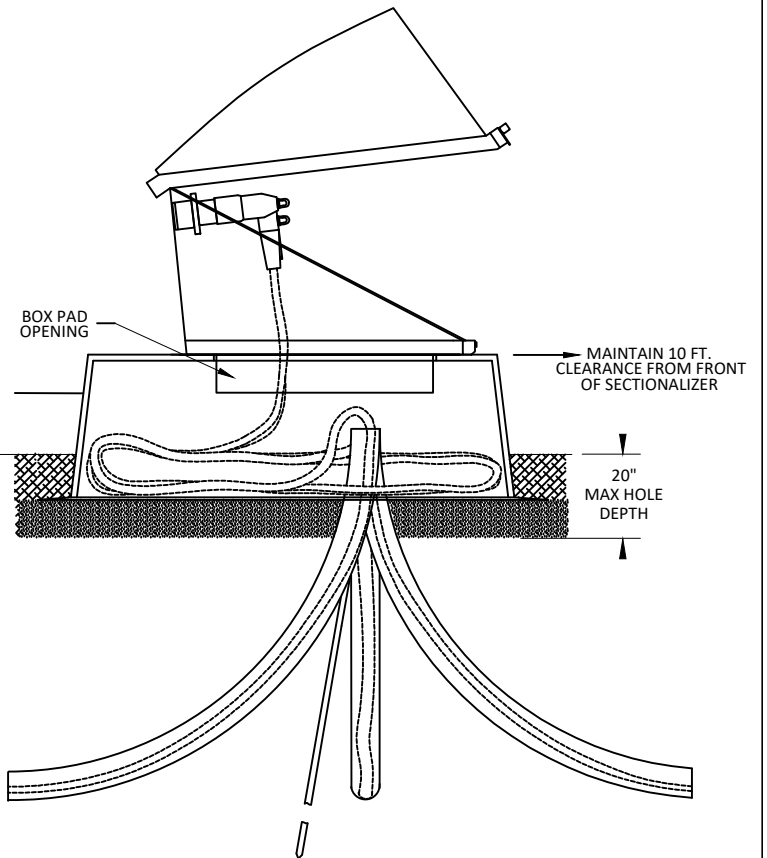

FRONT VIEW

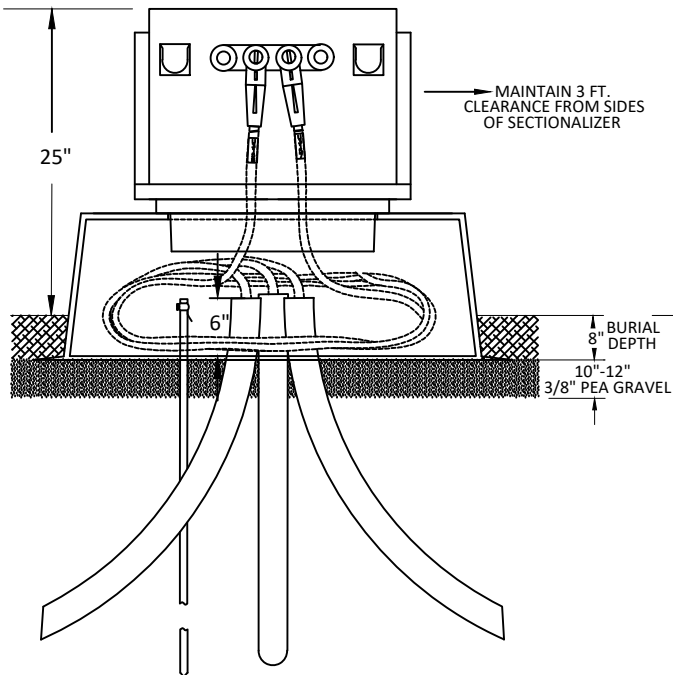

# 3PH TRANSFORMER PAD 45 - 750 KVA (UM3-A)

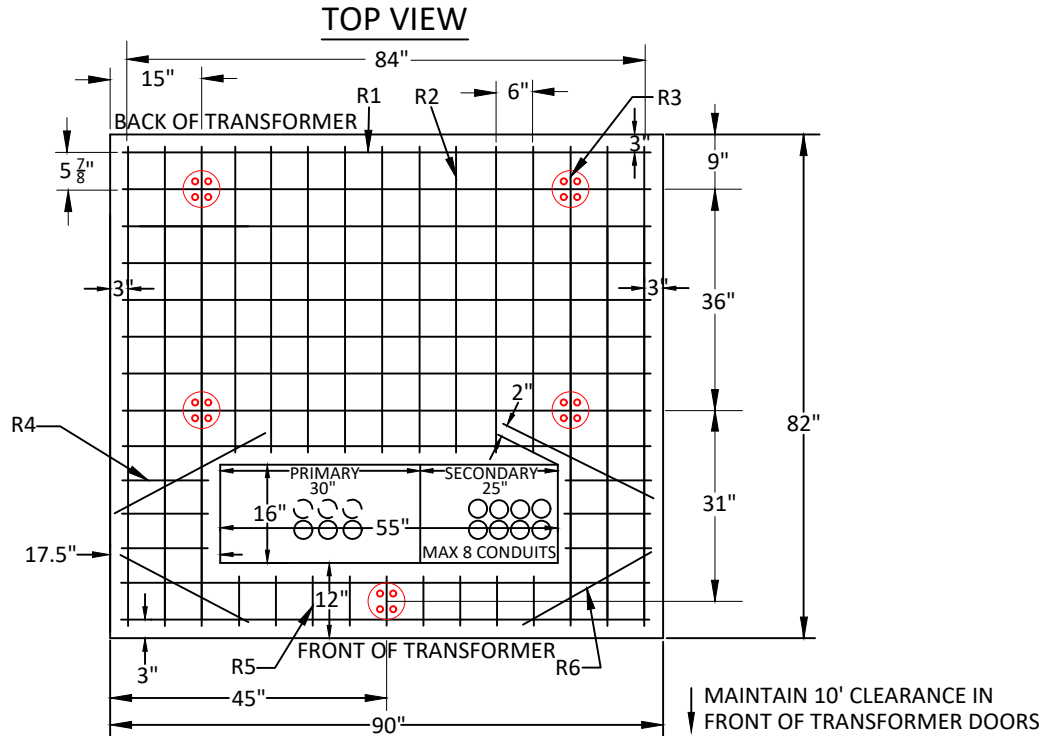

MAINTAIN CLEARANCE FROM TRANSFORMER SIDES:  
 OTHER TRANSFORMERS - 5 FT.  
 NON-COMBUSTIBLE WALLS - 5 FT.  
 COMBUSTIBLE WALLS:  
 0 TO 75 KVA - 10 FT.  
 >75 KVA - 20 FT.

**FRONT VIEW**

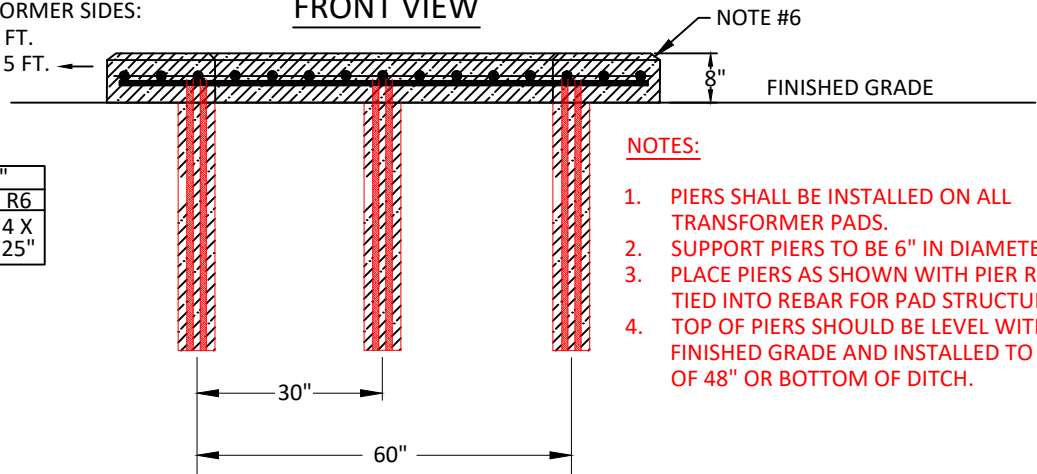

REINFORCING BARS; 1/2"					
R1	R2	R3	R4	R5	R6
11 X 86"	9 X 50"	6 X 78"	6 X 14"	9 X 8"	4 X 25"

SEE NOTE #3

**NOTES:**

1. PIERS SHALL BE INSTALLED ON ALL TRANSFORMER PADS.
2. SUPPORT PIERS TO BE 6" IN DIAMETER.
3. PLACE PIERS AS SHOWN WITH PIER REBAR TIED INTO REBAR FOR PAD STRUCTURE.
4. TOP OF PIERS SHOULD BE LEVEL WITH FINISHED GRADE AND INSTALLED TO A DEPTH OF 48" OR BOTTOM OF DITCH.

ANY CONDUITS STUBBED OUT FOR FUTURE USE SHALL EXTEND A MINIMUM OF 5' FROM EQUIPMENT. ENDS SHALL BE MARKED WITH 3" DIAMETER GREY PVC CONDUIT, EXTENDING 4' ABOVE GRADE AND PAINTED RED.

**NOTES:**

1. TAMP GROUND UNDER PAD BEFORE SETTING TO PREVENT UNEVEN SETTLING.
2. CONCRETE: 3000 POUNDS MIN. PER SQUARE INCH; 4% TO 6% ENTRAINED AIR, 3/4" MAX. SIZE AGGREGATE.
3. REINFORCING STEEL: ATSM-A615 GRADE 60; EVENLY SPACE APPROXIMATELY 6" O.C. EACH WAY AND SECURELY TIED TOGETHER.
4. MINIMUM 2 INCH CONCRETE COVER OVER REINFORCING STEEL.
5. WOOD FLOAT LEVEL FINISH LEAVING NO DEPRESSIONS.
6. 3/4" CHAMFER ALL EDGES.
7. PRIMARY AND SECONDARY CONDUIT SHALL BE INSTALLED AND SEALED BEFORE POURING PAD.
8. IF FUTURE EXPANSION TO A TRANSFORMER LARGER THAN 750 KVA IS POSSIBLE, BLUEBONNET MAY REQUEST THE CONSTRUCTION OF THE PAD ON PAGE B-6.
9. **MAXIMUM OF 8 CONDUITS, 4" SCHEDULE 40 PVC PIPES ARE ALLOWED IN THE SECONDARY COMPARTMENT.**
10. STUB THE SECONDARY PIPES AS CLOSE TO THE EDGE SECONDARY CUTOUT AS POSSIBLE. (SEE DRAWING)
11. MAXIMUM OF 6 CONDUITS, 3" SCHEDULE 40 PVC PIPES ARE ALLOWED IN THE PRIMARY COMPARTMENT.

# 3PH TRANSFORMER PAD 1000 - 2500 KVA (UM3-B)

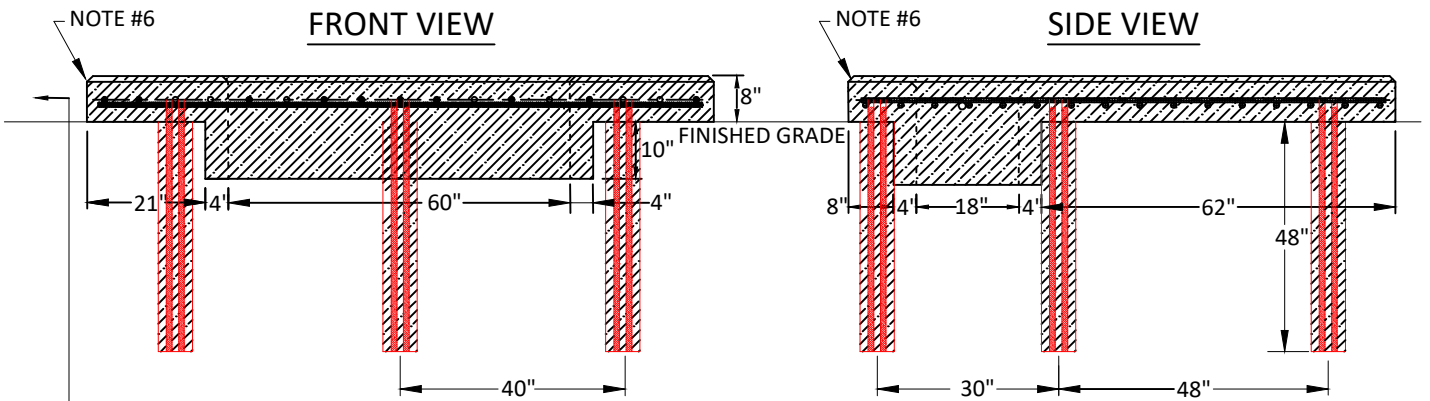
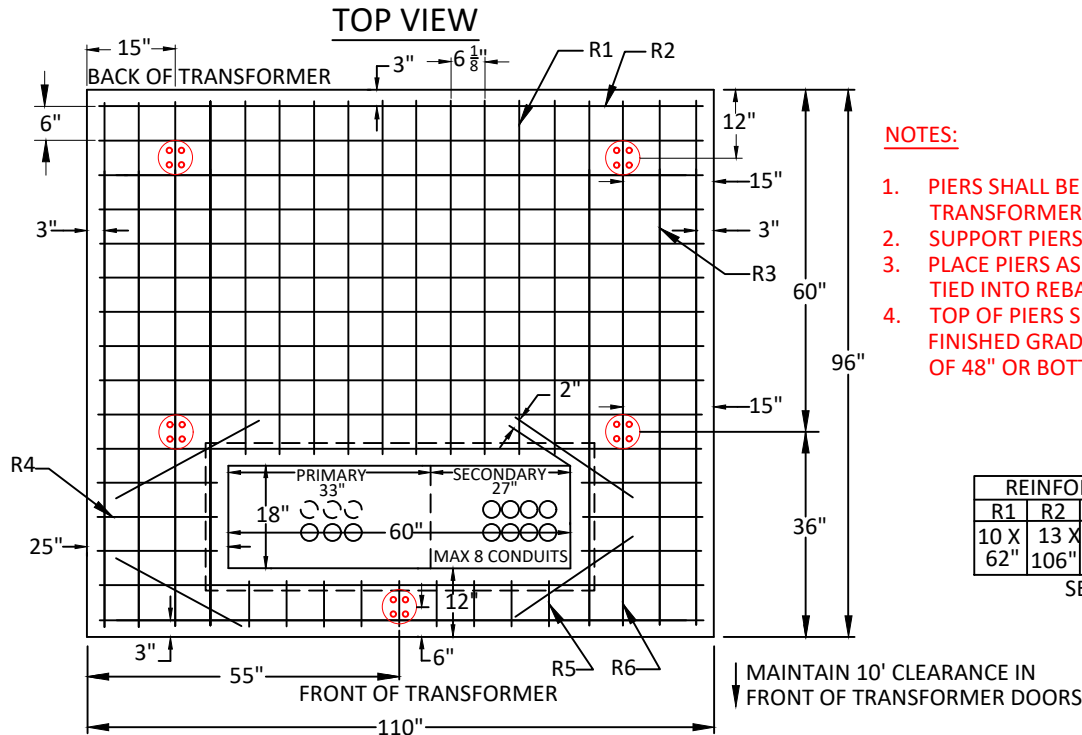

- NOTES:**
1. TAMP GROUND UNDER PAD BEFORE SETTING TO PREVENT UNEVEN SETTLING.
  2. CONCRETE: 3000 POUNDS MIN. PER SQUARE INCH; 4% TO 6% ENTRAINED AIR, 3/4" MAX. SIZE AGGREGATE.
  3. REINFORCING STEEL: ATSM-A615 GRADE 60; EVENLY SPACE APPROXIMATELY 6" O.C. EACH WAY AND SECURELY TIED TOGETHER.
  4. MINIMUM 2 INCH CONCRETE COVER OVER REINFORCING STEEL.
  5. WOOD FLOAT LEVEL FINISH LEAVING NO DEPRESSIONS.
  6. 3/4" CHAMFER ALL EDGES.
  7. PRIMARY AND SECONDARY CONDUIT SHALL BE INSTALLED AND SEALED BEFORE POURING PAD.
  8. MAXIMUM OF 8 CONDUITS, 4" SCHEDULE 40 PVC PIPES ARE ALLOWED IN THE SECONDARY COMPARTMENT.
  9. STUB THE SECONDARY PIPES AS CLOSE TO THE EDGE SECONDARY CUTOUT AS POSSIBLE. (SEE DRAWING)
  10. MAXIMUM OF 6 CONDUITS, 3" SCHEDULE 40 PVC PIPES ARE ALLOWED IN THE PRIMARY COMPARTMENT.

# 3PH 600A SECTIONALIZER - DIMENSIONS

TOP VIEW

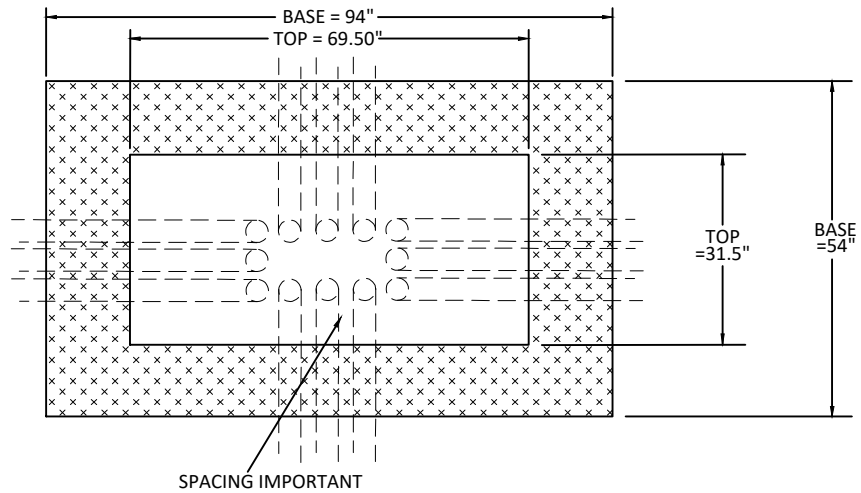

FRONT VIEW

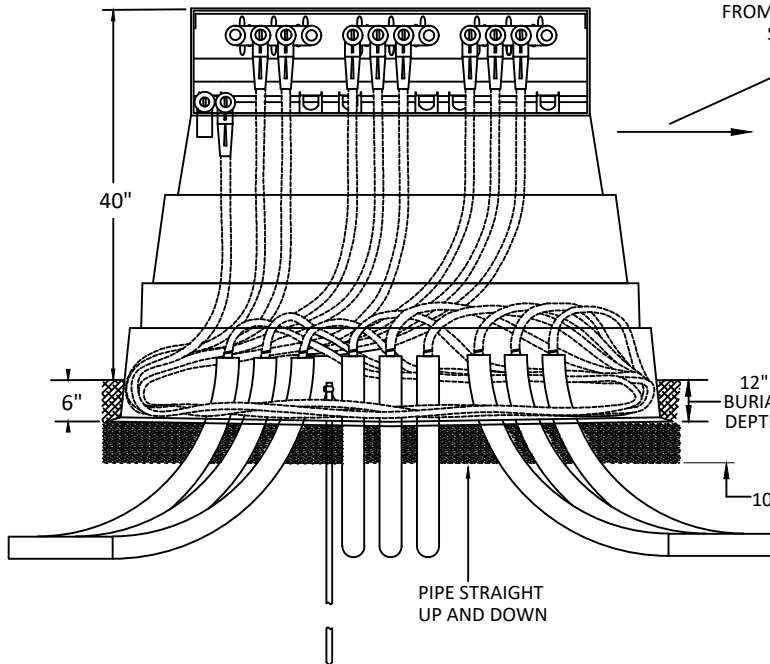

MAINTAIN 3 FT. CLEARANCE FROM SIDES AND BACK OF SECTIONALIZER.

SIDE VIEW

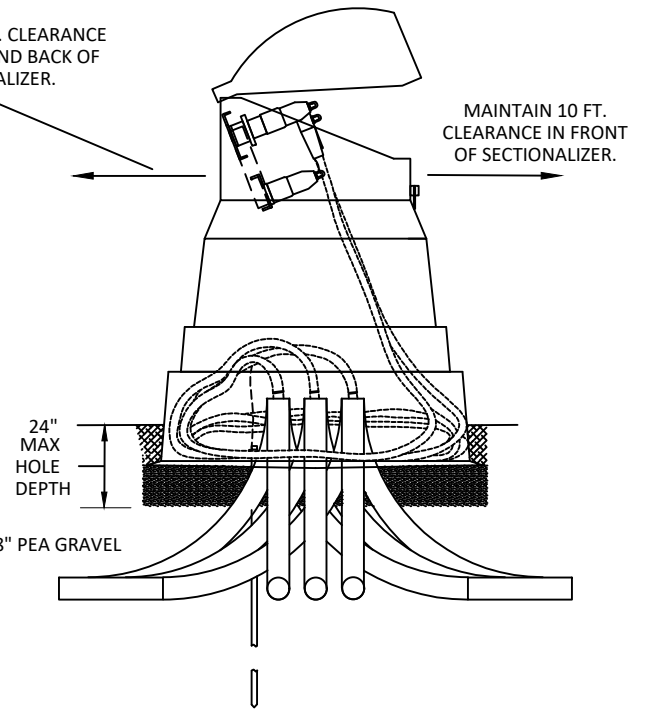

ANY CONDUITS STUBBED OUT FOR FUTURE USE SHALL EXTEND A MINIMUM OF 5' FROM EQUIPMENT. ENDS SHALL BE MARKED WITH 3" DIAMETER GREY PVC CONDUIT, EXTENDING 4' ABOVE GRADE AND PAINTED RED.

# SECONDARY JUNCTION BOX CONSTRUCTION STANDARD

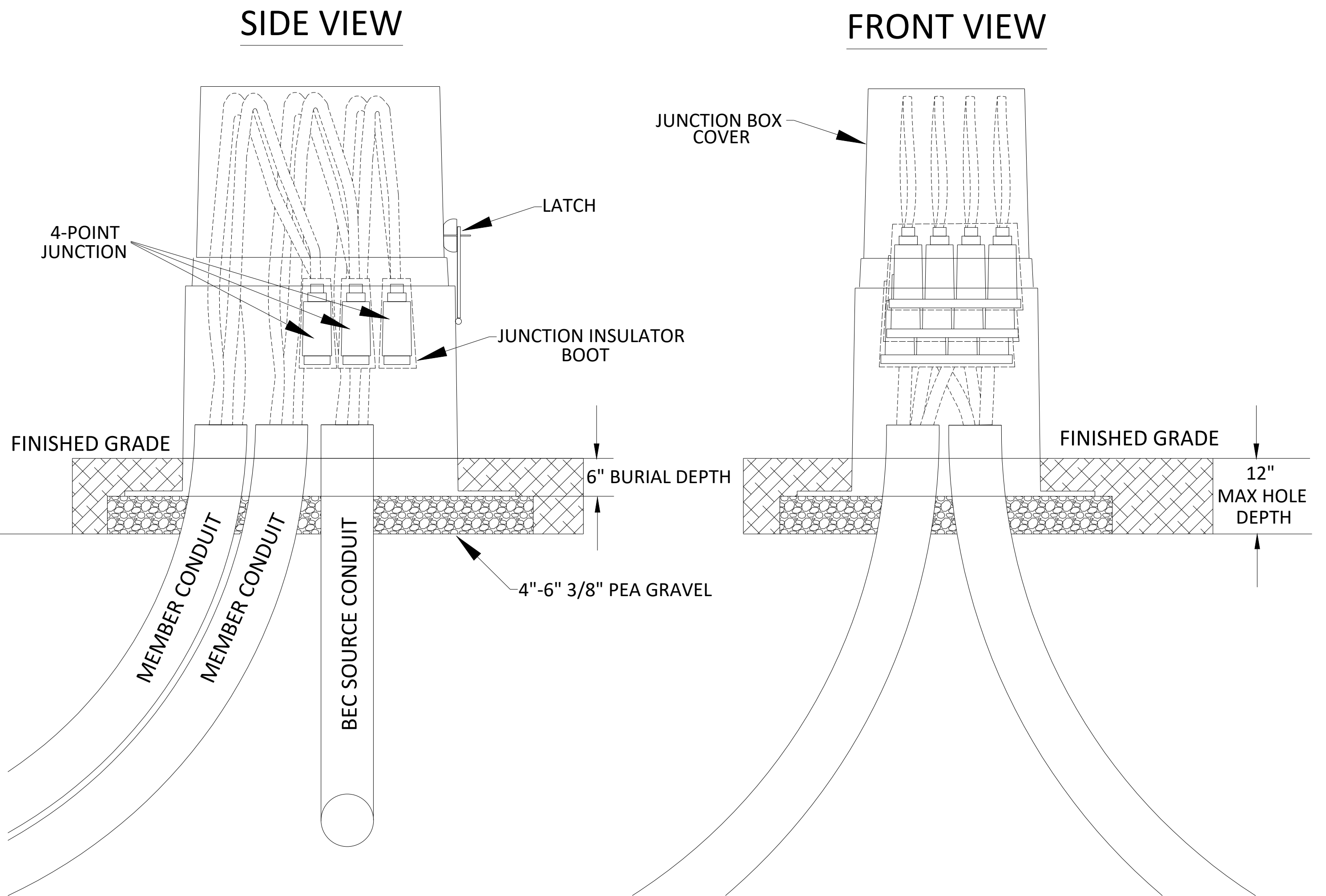

**NOTES:**

1. A MAXIMUM OF 1 INPUT AND 3 TRIPLEX OUTPUTS AND CAN BE CONNECTED IN JUNCTION BOX. MAX CABLE SIZE CONNECTOR ACCOMMODATES 350 KCM.
2. INSTALL INSULATED PROTECTIVE BOOT ON ALL SECONDARY JUNCTIONS.
3. EVENLY DISPERSE 4OZ. OF INSECTICIDE GRANULES IN PAD OPENING.

UJB SECONDARY JUNCTION BOX	INSECTICIDE GRANULES
UJ1-4A OR UJ1-4B 4PT SECONDARY JUNCTION BOX - QTY 3	U3P90-48 PVC ELBOW
GRAVEL	ID TAGS, COLORED TAPE, LABELS

# SECONDARY JUNCTION BOX DIMENSIONS

TOP VIEW

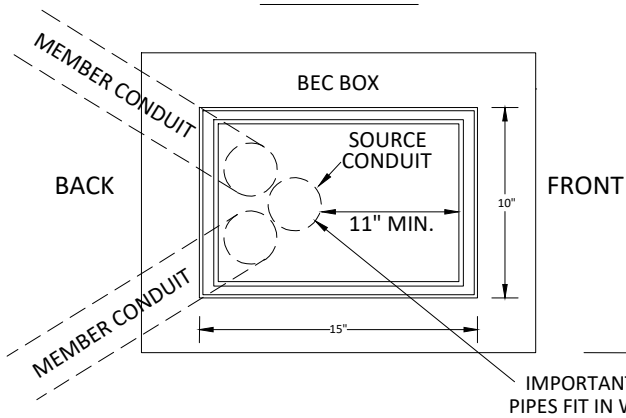

MEMBER SHALL PROVIDE 2" OR 3" SCH 40 PVC CONDUIT ELBOW WITH 10' OF ADDITIONAL CABLE RUN.

MAX ONE CONDUIT PER MEMBER UNLESS WRITTEN APPROVAL BY BEC PERSONNEL.

IMPORTANT THAT PIPES FIT IN WINDOW

SIDE VIEW

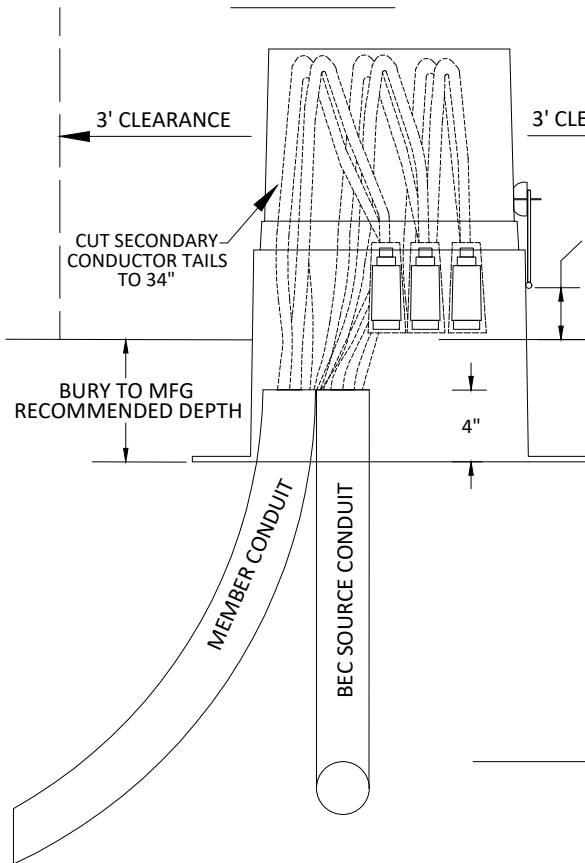

FRONT VIEW

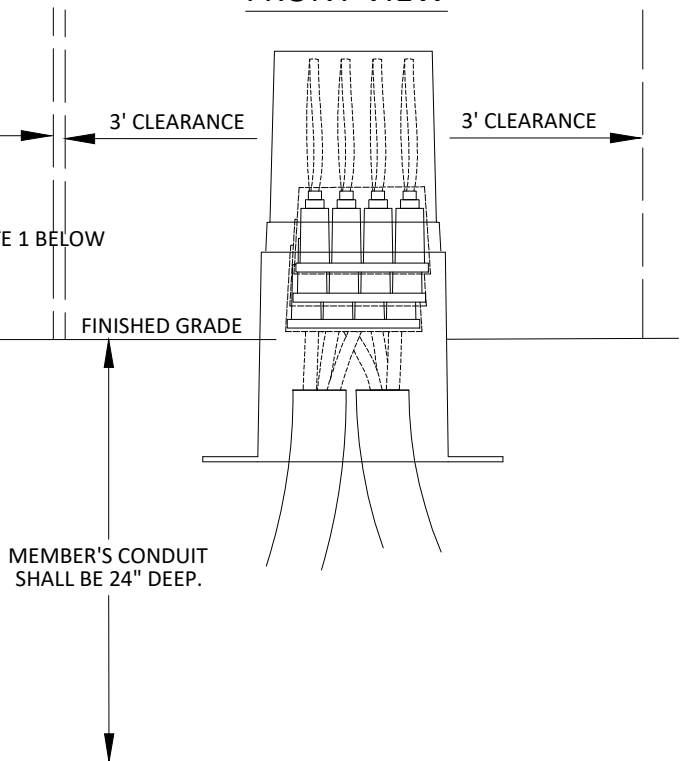

**NOTES:**

1. LATCH AND LOCK SHALL REMAIN ABOVE GROUND LEVEL.
2. MAINTAIN 3FT CLEARANCE FROM ALL SIDES OF JUNCTION BOX.

# USGE-9 SWITCHGEAR CONSTRUCTION STANDARD

SOURCE

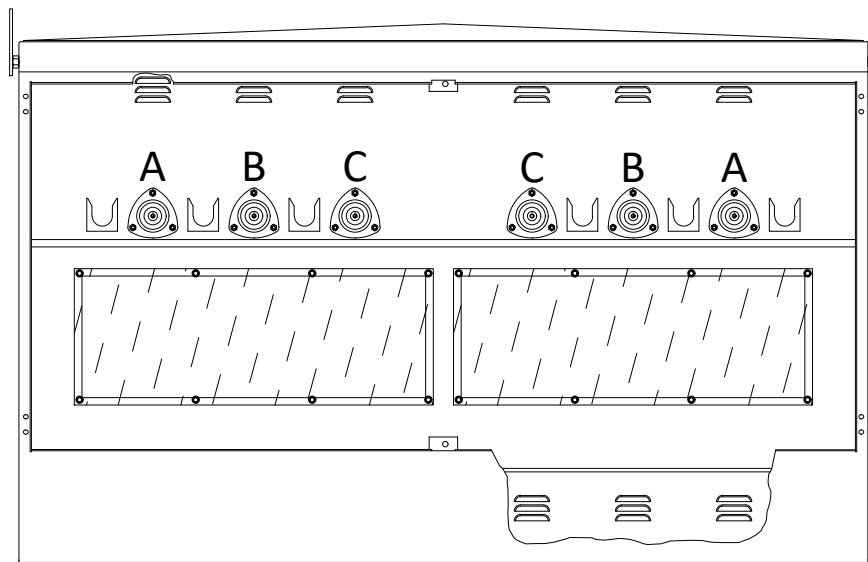

TAP

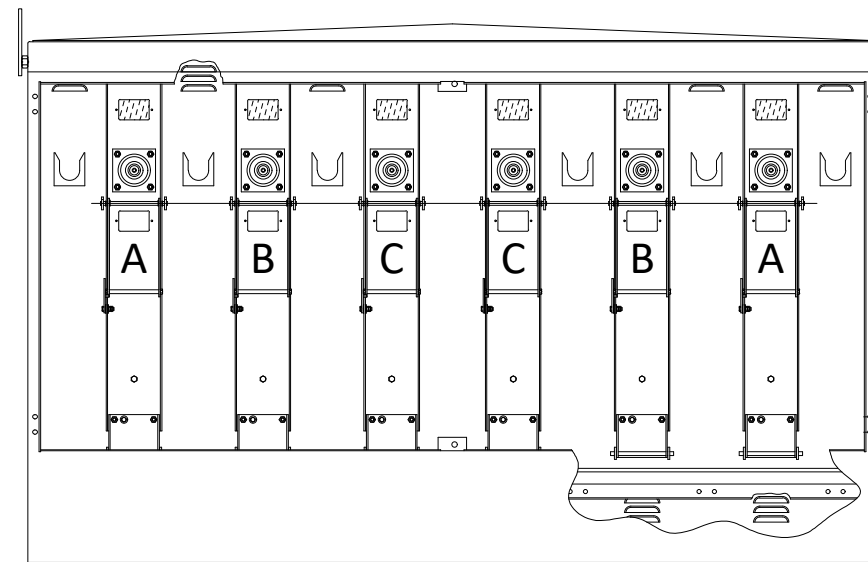

FRONT VIEW

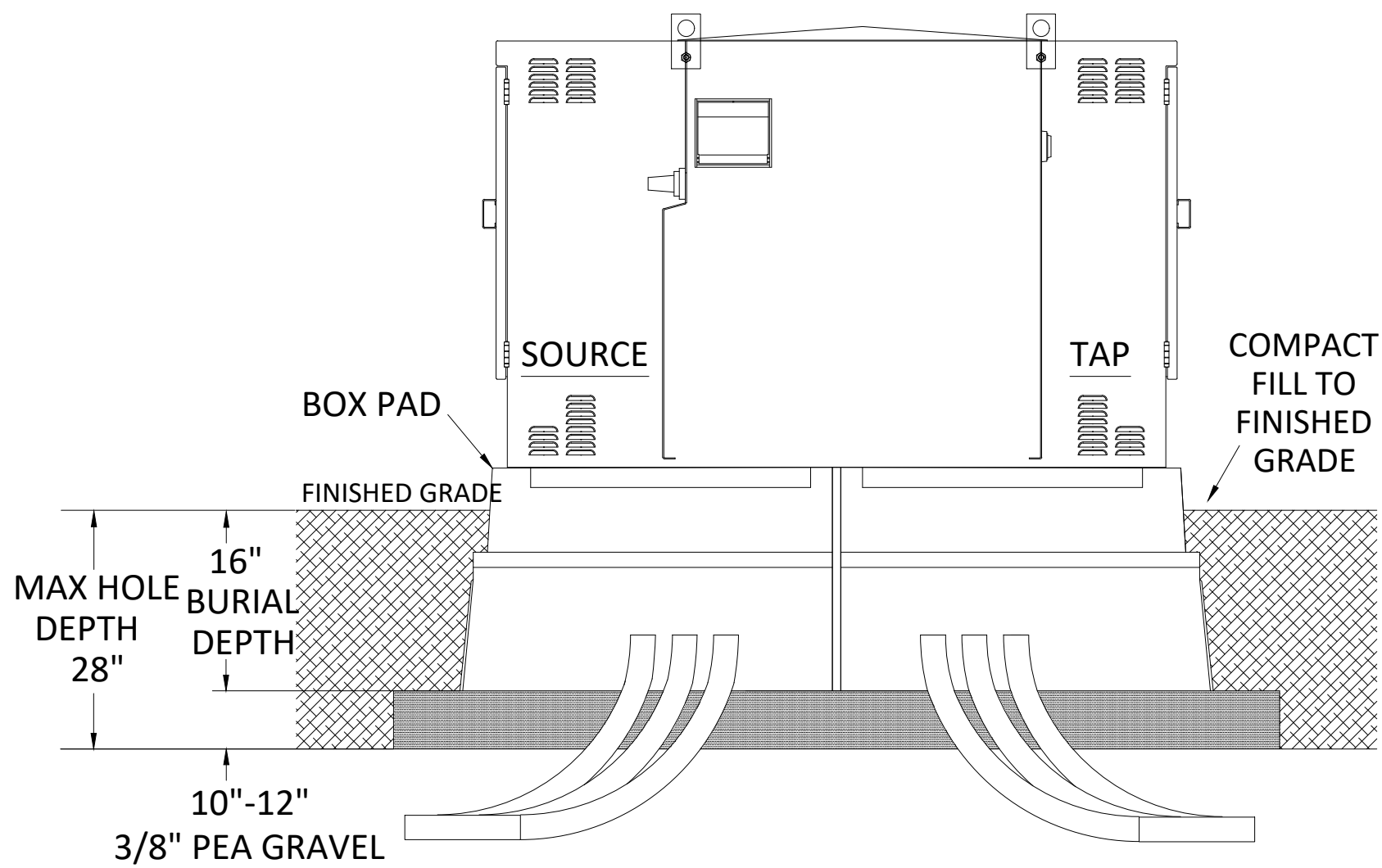

TOP VIEW

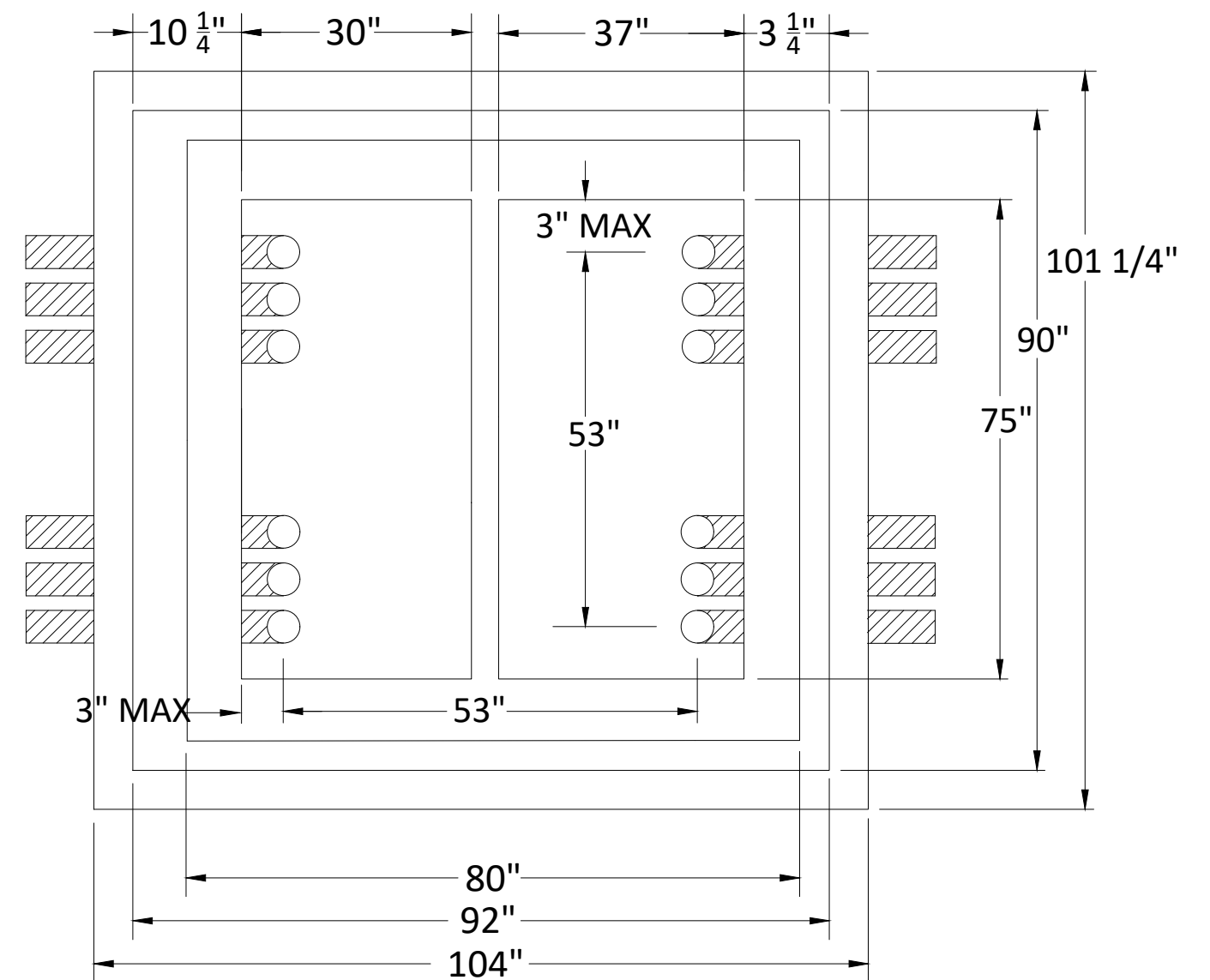

BEC STK#:	QTY:	MATERIAL USGE-9:
13119	1	SWITCHGEAR, AIR, 2-200 FUSE, 2-600 SWITCHES
10988	2	ROD, GROUND 5/8" X 8', 13 MIL CU CLAD
10262	2	CLAMP, GRD ROD GALV 3/4 L
10333	13	CONN, SPLIT BOLT CC #2 L
11196	6.148 lbs	WIRE, COPPER BARE S.D. #2 7 STR L
10732	4	INSECTICIDE ANT CONTROL L
10779	6	LOCK, PADLOCK, STANDARD WITH BEC LOGO
10386	6	CONN,INSUL.L.B.PARKING STAND L
10237	6	CAPS, ASSY GRD TERMINATION L
11202	26.12 lbs	WIRE, COPPER BARE 4/0 19 STR L
10172	6	BUSHING, LB INSERT 25KV L
14300	6	FITTING, FUSE END, SM-20, 15/25 KV L

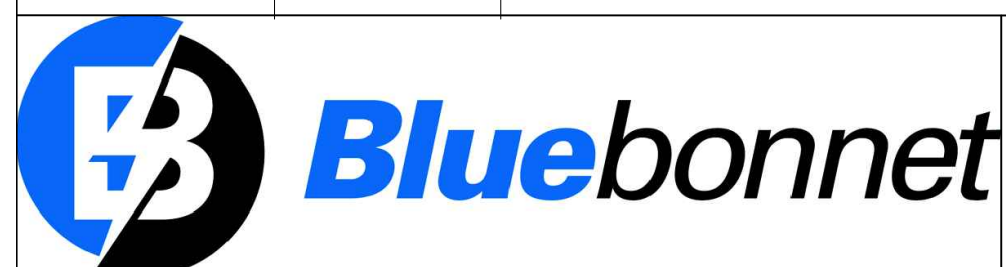

DATE APPROVED:  
June 24, 2025

UNDERGROUND DISTRIBUTION

# USGE-10 SWITCHGEAR CONSTRUCTION STANDARD

SOURCE

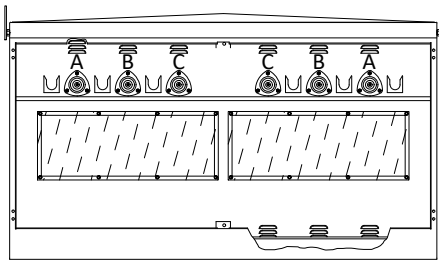

TAP

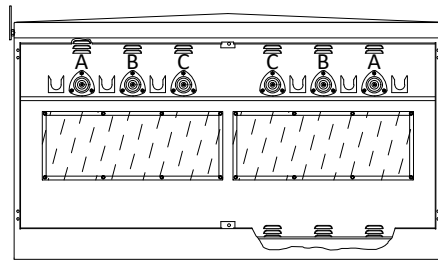

FRONT

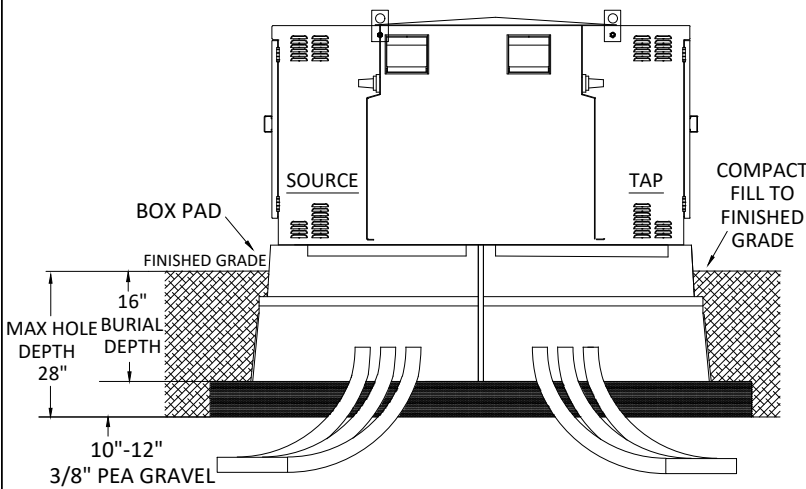

TOP VIEW

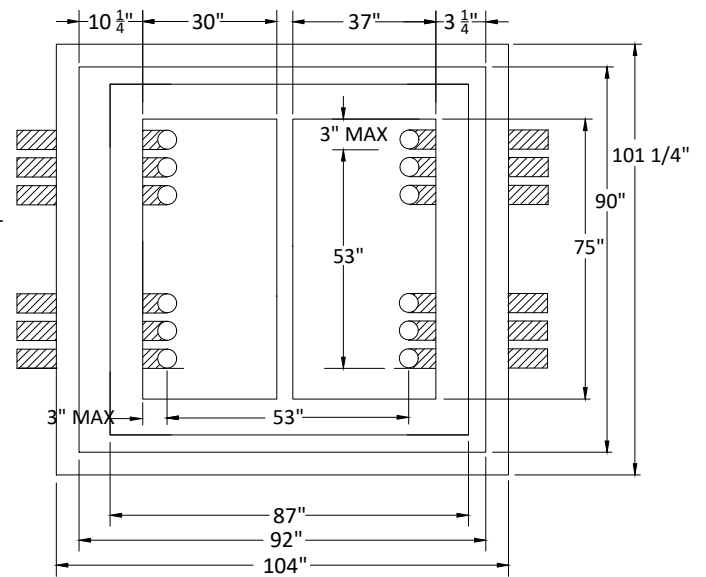

BEC STK#:	QTY:	MATERIAL USGE-10:
13130	1	SWITCHGEAR, AIR, PADMOUNTED, 4-600 SWITCHES
10988	2	ROD, GROUND 5/8" X 8', 13 MIL CU CLAD
10262	2	CLAMP, GRD ROD GALV 3/4 L
10333	13	CONN, SPLIT BOLT CC #2 L
11196	6.148 lbs	WIRE, COPPER BARE S.D. #2 7 STR L
10732	4	INSECTICIDE ANT CONTROL L
10779	10	LOCK, PADLOCK, STANDARD WITH BEC LOGO
11202	26.12 lbs	WIRE, COPPER BARE 4/0 19 STR L



DATE APPROVED:  
JUNE 24, 2025

UNDERGROUND DISTRIBUTION

# USGE-11 SWITCHGEAR CONSTRUCTION STANDARD

SOURCE

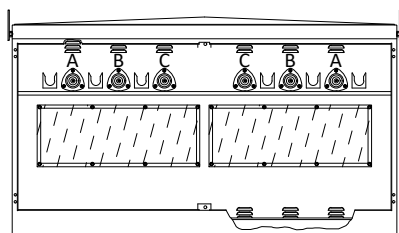

TAP

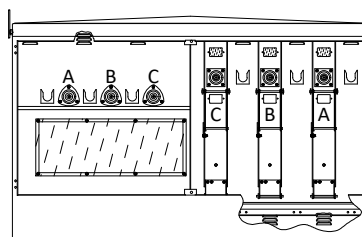

FRONT

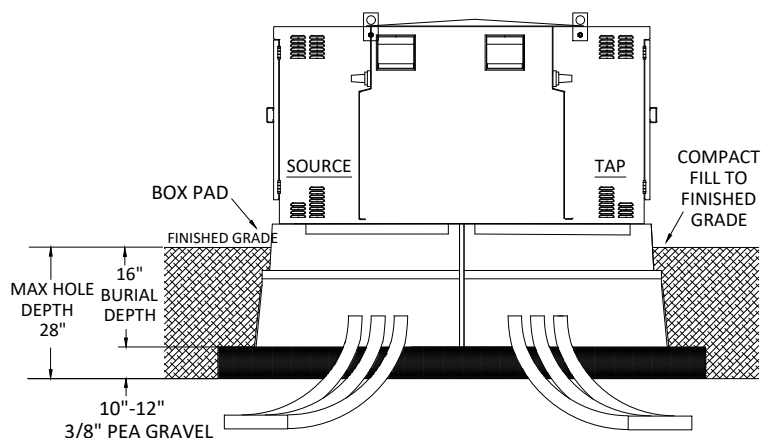

TOP VIEW

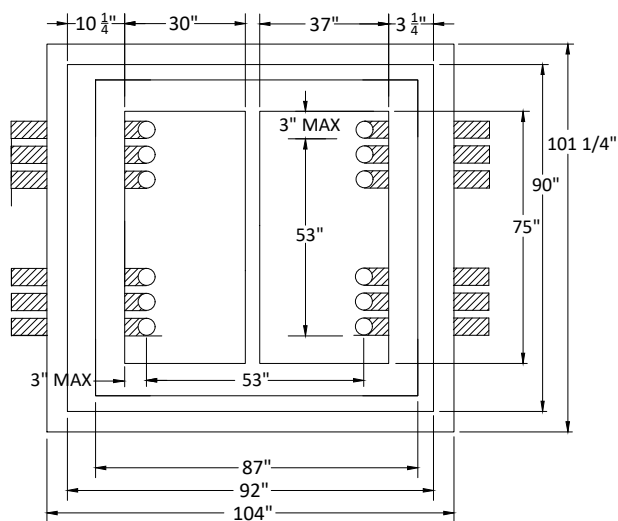

BEC STK#:	QTY:	MATERIAL USGE-11:
12971	1	SWITCHGEAR, AIR, 1-200 FUSE, 3-600 SWITCHES
10988	2	ROD, GROUND 5/8" X 8', 13 MIL CU CLAD
10262	2	CLAMP, GRD ROD GALV 3/4 L
10333	13	CONN, SPLIT BOLT CC #2 L
11196	6.148 lbs	WIRE, COPPER BARE S.D. #2 7 STR L
10732	4	INSECTICIDE ANT CONTROL L
10779	8	LOCK, PADLOCK, STANDARD WITH BEC LOGO
10386	3	CONN,INSUL.L.B.PARKING STAND L
10237	3	CAPS, ASSY GRD TERMINATION L
11202	26.12 lbs	WIRE, COPPER BARE 4/0 19 STR L
10172	3	BUSHING, LB INSERT 25KV L
14300	3	FITTING, FUSE END, SM-20, 15/25 KV L



DATE APPROVED:  
JUNE 24, 2025

UNDERGROUND DISTRIBUTION

## Metering Guidelines

Latest Update to all specs can be found at [Bluebonnetelectric.coop](http://Bluebonnetelectric.coop)

**For the member's safety, wiring installation and material shall conform to the requirements of the NEC, TDLR and NESC. All Wiring Installations must also meet local guidelines, if applicable, set forth but the city, county, or other governing entity in the event these requirements are more stringent than Bluebonnet specifications.**

### General Notes

Applicable to All Specs

1. Weatherproof fittings are required for all connections.
2. The main electrical disconnect for each electrical service, if not mounted on a Bluebonnet pole or on an approved rack, shall be unenclosed and installed on the exterior of the building or approved structure in a location approved by Bluebonnet Electric Cooperative
3. Meter assembly must remain unenclosed on the exterior of a structure.
4. Meter assembly cannot be mounted on a mobile home.
5. Any part of a meter rack or equipment rack shall be a minimum of six feet from Bluebonnet poles or equipment, and shall not impede access for maintenance to Bluebonnet's poles or equipment.
6. Bluebonnet poles must remain free of structures and private attachments other than the meter loop/meter loop riser assembly.
7. Meter loops or risers shall be installed on pole by Bluebonnet.
8. All secondary connections are to be made by Bluebonnet.
9. Neutral(s) must be insulated and may only be reduced two sizes on residential applications. No reduction of the neutral(s) is allowed on commercial applications.
10. Each phase must be sized to accommodate the total main fuses or breakers installed
11. Electric service to fire pumps shall be served through a CT-metered service.
12. Where three-phase is used to provide single-phase service to individual occupants, the load must be balanced between all three phases as equally as possible. This applies whether the single phase services are individually metered or not.
13. For all jobs requiring excavation, including rack or underground, the individual or contractor performing the work shall call TEXAS811 for locating jobs before digging to Bluebonnet equipment. No private utilities will be located.
14. Mobile Home Feeder Cables may not be used from Transformer or UJB to Meter unless the fourth (Green or Bare) Ground wire can be and is removed before installing.
15. If Communication lines are present, 43" of clearance must be maintained between the lowest energized equipment and communication line. Equipment includes but is not limited to drip loops, neutral, transformers, etc.
16. Meter sockets not furnished by Bluebonnet will need to be ringless.

## CT Metering Notes

**Applies to:** MS-112B1, MS-112B3, MS-113B1, MS-113B3, MS-114A1, MS-114B3, MS-115-1, MS-115-3, MS-202A1, MS-202B3, MS-204B1, MS-204B2, MS-204B3, MS-207B, MS-301B, MS-301C, MS-406A, MS-533-1, MS-533-3, MS-554-1, MS-554-3

1. CT Enclosures may be purchased from Techline **(512-332-2978)** and Installed by Member:  
Minimum Size 1 Phase: Main Enclosure 30" x 30" x 12"  
Backup Enclosure 24" x 30" x 13"  
Minimum Size 3 Phase: Main Enclosure 42" x 30" x 13"  
Backup Enclosure 24" x 30" x 13"
2. CT enclosures may be purchased at any supplier as long as it meets the minimum dimensions and is able to accommodate a Bluebonnet pad lock.
3. Bluebonnet to provide CTs.
4. The electrical contractor will notify Bluebonnet 72 hours in advance to schedule Bluebonnet personnel to deliver the CT's. The electrician shall install the CT's on the rack with the correct polarity before the conductor is brought through the CT enclosure. Call **(800-842-7708)** to schedule a connect.
5. Electric service to fire pumps shall be served through a CT-metered service.

## Standby Generator Notes

**Applies to:** MS-400, MS-401, MS-401A, MS-402, MS-402A, MS-403, MS-404, MS-405, MS-406, MS-406A, MS-407, MS-408, MS-412

1. Generators shall be placed a minimum of 15' away from Bluebonnet's pole(s) and/or equipment and outside of Bluebonnet's easement.
2. Transfer switches may be on Bluebonnet pole, only if they are in place of a main panel. They may not be in addition to a panel.
3. Any transfer switch that serves as a main (first device past meter) must be service rated
4. Generators must be connected with a dedicated transfer switch. Breaker interlocks are not acceptable.
5. Portable generators may be connected to an inlet through a transfer switch.
6. Transfer switches that plug into the meter base are not acceptable.

## Renewable Energy Connection Notes

**Applies to:** MS-501, MS-502, MS-507T, MS-553-1, MS-553-3, MS-554-1, MS-554-3, MS-41115, MS-41119

1. The solar and/or battery disconnect(s), if not mounted on an approved rack, shall be installed on the exterior of the building or approved structure in a location approved by Bluebonnet Electric Cooperative.
2. DG disconnect must be clearly labeled and identified.
3. Bluebonnet poles must remain free of structures and private attachments other than the meter loop assembly or riser.
4. Inspection may be required by local jurisdiction if applicable.
5. DG meter or equipment rack (If Applicable) shall be a minimum of 6' away from Bluebonnet's poles and/or equipment.
6. Any installation with Batteries are required to have an accessible disconnect or method of shutdown to disable batteries.

**SELF CONTAINED (200 AMPS OR LESS)**

**CT. RATED (LARGER THAN 200 AMPS)**

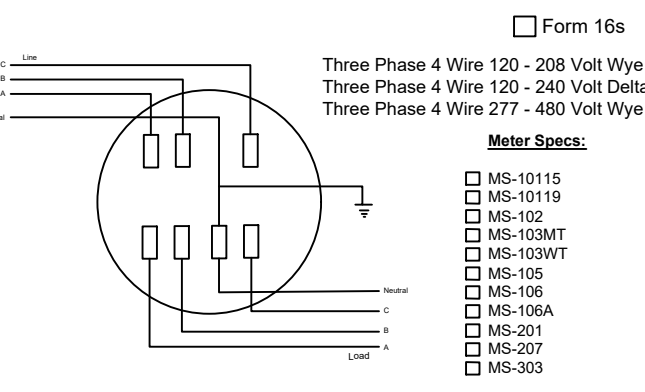
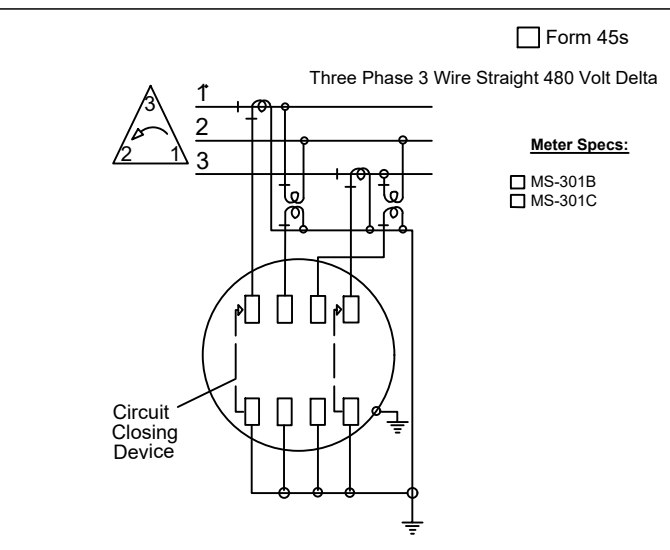
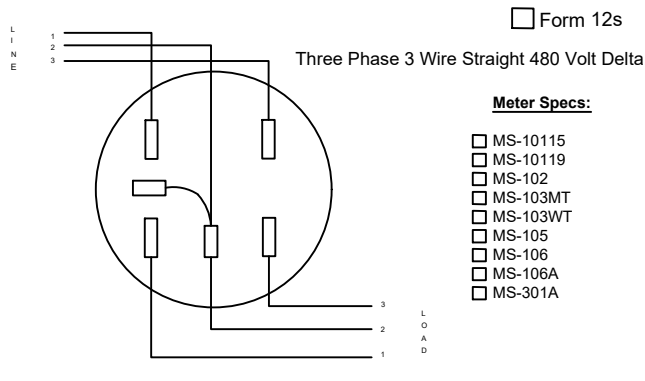
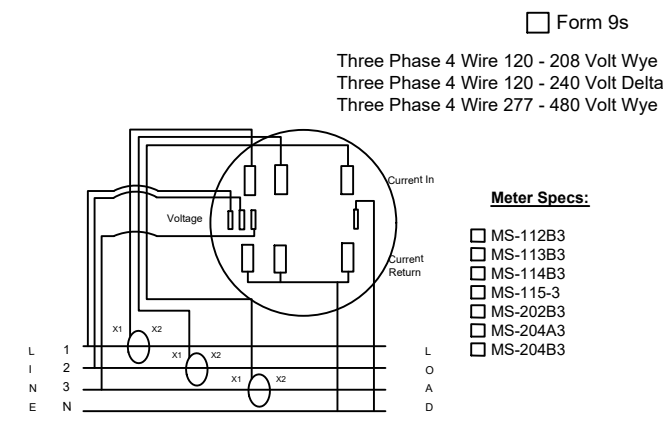
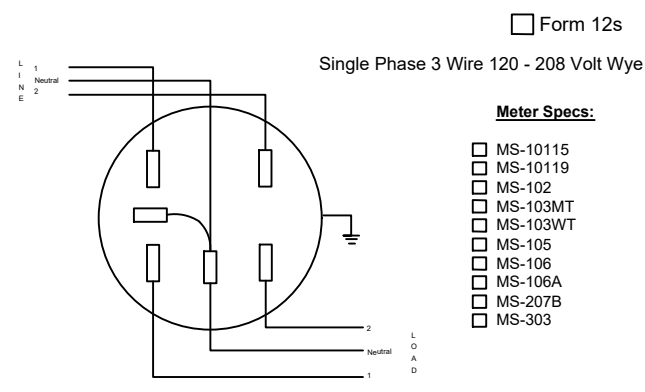
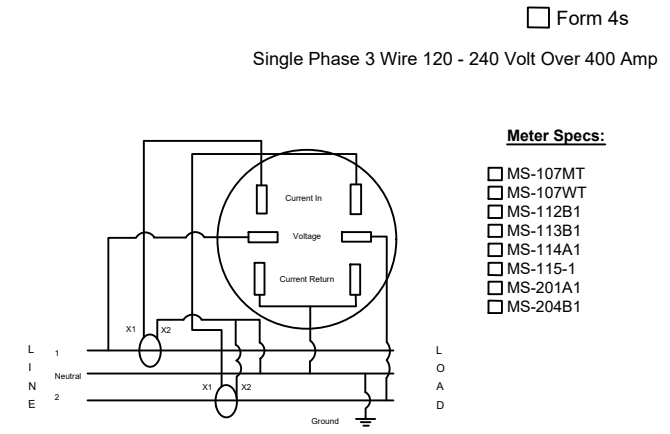
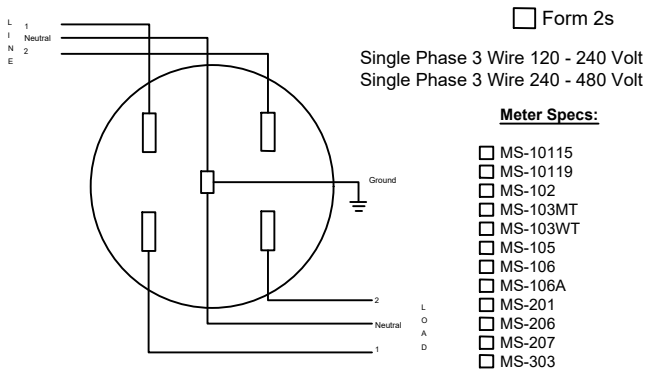

**METER BASES**

drawn:	approved:	date:	-----
JW	Standards	Jan. 30, 2024	

**Notes:**

1. This meter loop specification is good for the following voltages: 120/240, 120/208, 240/480 & 277/480. Please use MS-301 for straight 480 Delta applications only.
2. Bluebonnet Electric will supply ground rod.
3. On steel poles use a 3/8" X 1 1/2" self tapping screw.
4. For your safety, only Bluebonnet personnel are authorized to install meter loops or other BEC equipment on a Bluebonnet pole. Members shall have loop assembled and available for installation by Bluebonnet.
5. See "Metering Guidelines" for all other applicable notes.

**FOR SINGLE PHASE TRAFFIC CONTROL DEVICES:**

200amp, 4 terminal, 1-phase, will require a lever by-pass meeting ANSI C12.7, UL 414, and NEMA 3R rating. Lever by-pass is only required for meter installations serving traffic control devices, including railroad, that need to remain functional at all times.

**FOR THREE PHASE APPLICATIONS DESCRIPTION:**

200amp, 7 terminal, 3-phase, 4-wire will require a lever by-pass meeting ANSI C12.7, UL 414, and NEMA 3R. Meter cans are available for purchase through Techline or any other electrical supplier provided it meets all Bluebonnet Electric Cooperative specifications.

Galvanized metal conduit with (1) locknut and insulating bushing inside meter can on nipple and (1) locknut under meter can. Maintain 3-6" distance between the meter can and the disconnect. Member shall use a metal nipple. A Straight or offset nipple is acceptable.

#6 solid, bare ground wire and clamp attached to Bluebonnet's pole ground. Ground rod provided by Bluebonnet.

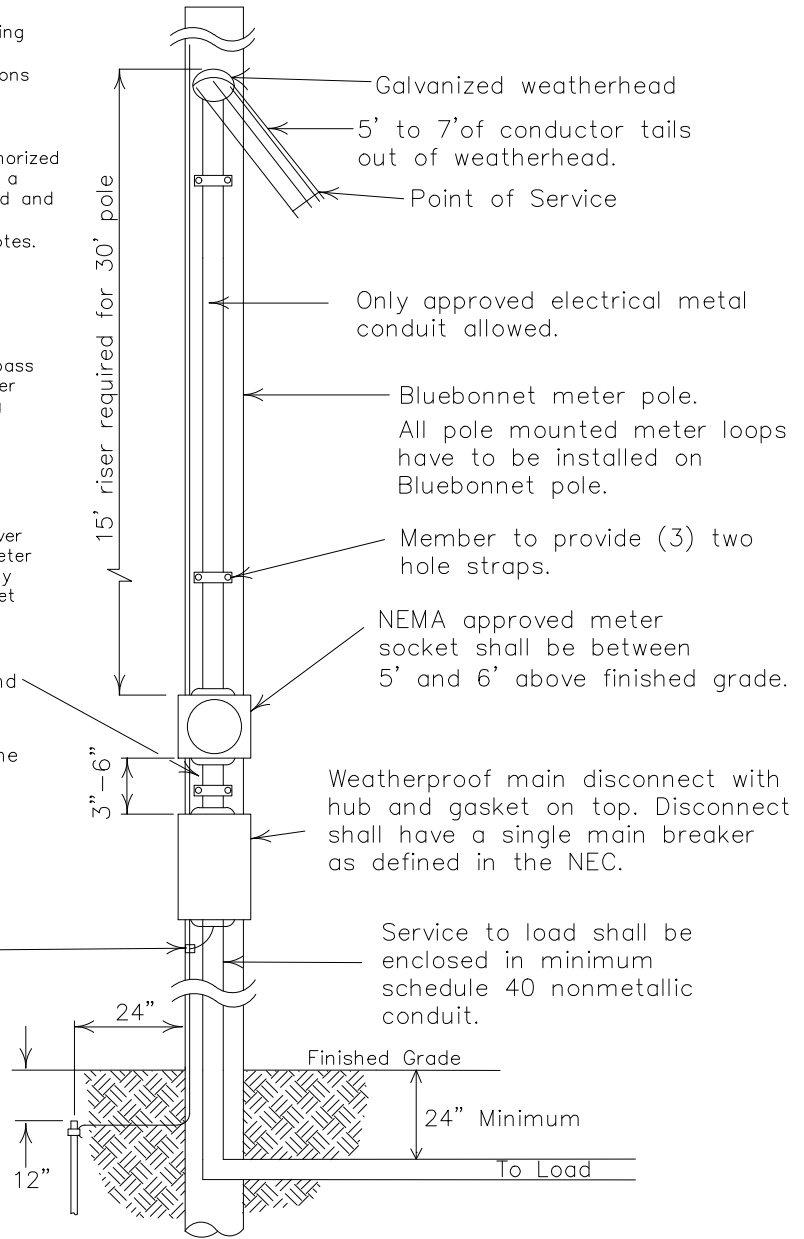

**CURRENT CARRYING CAPACITIES AND CONDUIT/NIPPLE SIZE REQUIREMENTS OF STANDARD WIRE SIZES (RHH, RHW, THW, THWN, THHN, AND XHHW) REFER TO NEC FOR OTHER CALCULATIONS.**

COPPER CONDUCTOR			ALUMINUM CONDUCTOR		
Wire Size	Breaker Size	Conduit/Nipple Size	Wire Size	Breaker Size	Conduit/Nipple Size
#6	60 Amp	1 1/4" Conduit	#4	60 Amp	1 1/4" Conduit
#4	100 Amp	1 1/4" Conduit	#2	100 Amp	1 1/4" Conduit
#2	125 Amp	1 1/2" Conduit	#1/0	125 Amp	1 1/2" Conduit
#1	150 Amp	2" Conduit	#2/0	150 Amp	2" Conduit
#2/0	200 Amp	2" Conduit	#4/0	200 Amp	2" Conduit

**15' METER LOOP**  
 1Ø OR 3Ø 60-200 AMP  
 METER LOOP ON METER POLE  
 (GOOD FOR VOLTAGES: 120/240, 120/208, 240/480, 277/480)



DATE	REVISIONS		Drawn By :	Checked By :	Approved By :
11-27-17	ADDED NIPPLE AFTER CONDUIT SIZE		RG	MS COMMITTEE	MS COMMITTEE
03-31-20	ADDED NOTE 7		Scale :	Date:	
11-04-21	ADDED MAIN BREAKER NOTE		NONE	11-04-2021	MS-10115

**Notes:**

1. This meter loop specification is good for the following voltages: 120/240, 120/208, 240/480 & 277/480. Please use MS-301 for straight 480 Delta applications only.
2. Bluebonnet Electric will supply ground rod.
3. On steel poles use a 3/8" X 1 1/2" self tapping screw.
4. For your safety, only Bluebonnet personnel are authorized to install meter loops or other BEC equipment on a Bluebonnet pole. Members shall have loop assembled and available for installation by Bluebonnet.
5. See "Metering Guidelines" for all other applicable notes.

FOR SINGLE PHASE TRAFFIC CONTROL DEVICES:  
 200amp, 4 terminal, 1-phase, will require a lever by-pass meeting ANSI C12.7, UL 414, and NEMA 3R rating. Lever by-pass is only required for meter installations serving traffic control devices, including railroad, that need to remain functional at all times.

FOR THREE PHASE APPLICATIONS DESCRIPTION:  
 200amp, 7 terminal, 3-phase, 4-wire will require a lever by-pass meeting ANSI C12.7, UL 414, an NEMA 3R. Meter cans are available for purchase through Techline or any other electrical supplier provided it meets all Bluebonnet Electric Cooperative specifications.

Galvanized metal conduit with (1) locknut and insulating bushing inside meter can on nipple and (1) locknut under meter can. Maintain 3-6" distance between the meter can and the disconnect. Member shall use a metal nipple. A Straight or offset nipple is acceptable.

#6 solid, bare ground wire and clamp attached to Bluebonnet's pole ground. Ground rod provided by Bluebonnet.

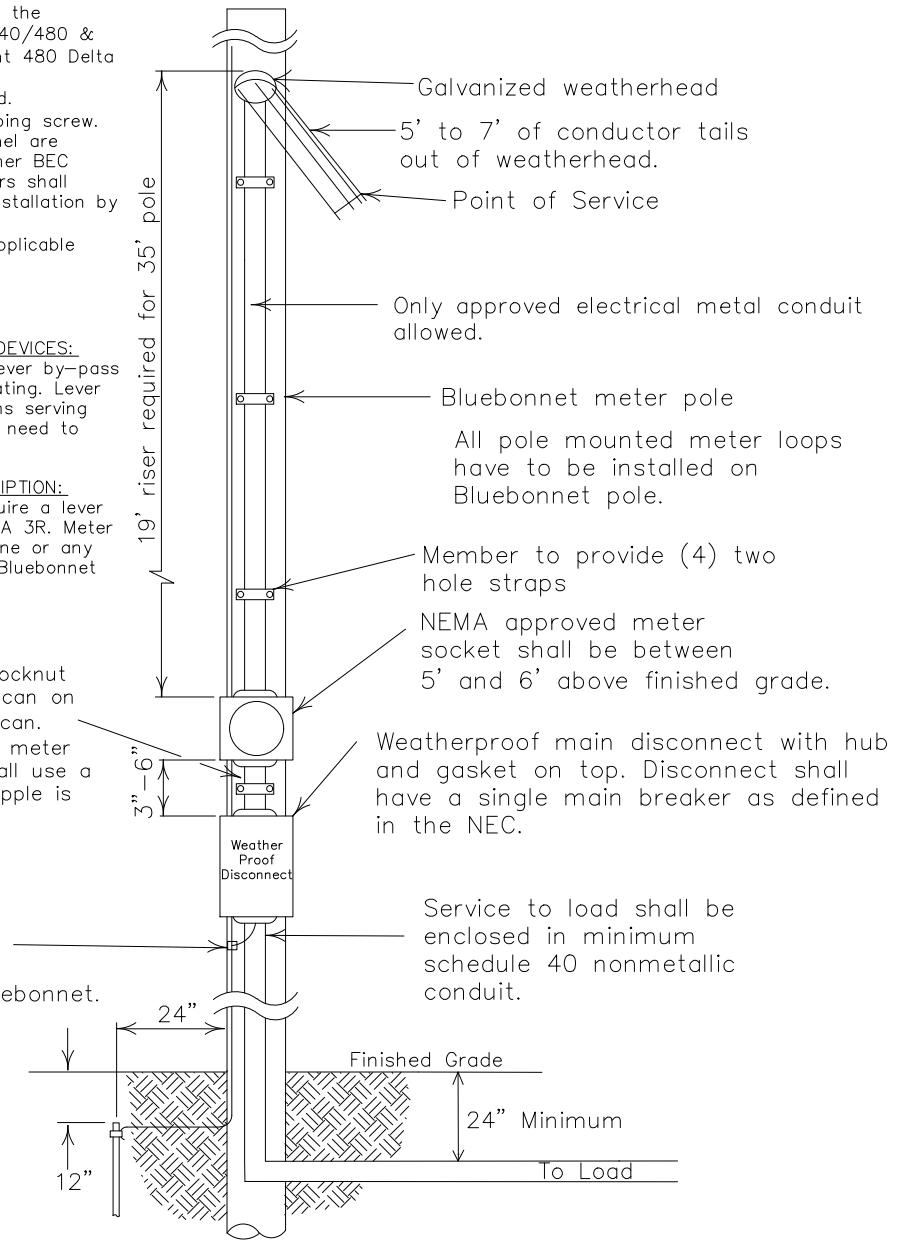

**CURRENT CARRYING CAPACITIES AND CONDUIT/NIPPLE SIZE REQUIREMENTS OF STANDARD WIRE SIZES**  
 (RHH, RHW, THW, THWN, THHN, AND XHHW)  
 REFER TO NEC FOR OTHER CALCULATIONS.

COPPER CONDUCTOR			ALUMINUM CONDUCTOR		
Wire Size	Breaker Size	Conduit/Nipple Size	Wire Size	Breaker Size	Conduit/Nipple Size
#6	60 Amp	1 1/4" Conduit	#4	60 Amp	1 1/4" Conduit
#4	100 Amp	1 1/4" Conduit	#2	100 Amp	1 1/4" Conduit
#2	125 Amp	1 1/2" Conduit	#1/0	125 Amp	1 1/2" Conduit
#1	150 Amp	2" Conduit	#2/0	150 Amp	2" Conduit
#2/0	200 Amp	2" Conduit	#4/0	200 Amp	2" Conduit

**19' METER LOOP**  
 1Ø OR 3Ø 60-200 AMP  
 METER LOOP ON METER POLE  
 (GOOD FOR VOLTAGES: 120/240, 120/208, 240/480, 277/480)



DATE	REVISIONS		Drawn By :	Checked By :	Approved By :
11-27-17	ADDED NIPPLE AFTER CONDUIT SIZE		RG	MS COMMITTEE	MS COMMITTEE
03-31-20	ADDED NOTE 7		Scale :	Date:	
11-04-21	ADDED MAIN BREAKER NOTE		NONE	11-04-2021	MS-10119

FOR THREE PHASE APPLICATIONS  
DESCRIPTION:

200amp, 7 terminal, 3-phase, 4-wire will require a lever by-pass meeting ANSI C12.7, UL 414, and NEMA 3R. Meter cans are available for purchase through Techline (Red Rock 512-332-2978) or any other electrical supplier provided it meets all Bluebonnet Electric Cooperative specifications.

FOR SINGLE PHASE  
TRAFFIC CONTROL DEVICES:

200amp, 4 terminal, 1-phase, will require a lever by-pass meeting ANSI C12.7, UL 414, and NEMA 3R rating. Lever by-pass is only required for meter installations serving traffic control devices, including railroad, that need to remain functional at all times.

Notes:

1. This meter loop specification is good for the following voltages: 120/240, 120/208, 277/480, 240/480 (Single phase only). Please use MS-301 for straight 480 Delta applications.
2. Bluebonnet Electric will supply ground rod.
3. On steel poles use a 3/8" x 1 1/2" self tapping screw.
4. For your safety, only Bluebonnet personnel are authorized to install meter loops or other BEC equipment on a Bluebonnet pole. Members shall have loop assembled and available for installation by Bluebonnet.
5. See "Metering Guidelines" for all other applicable notes.

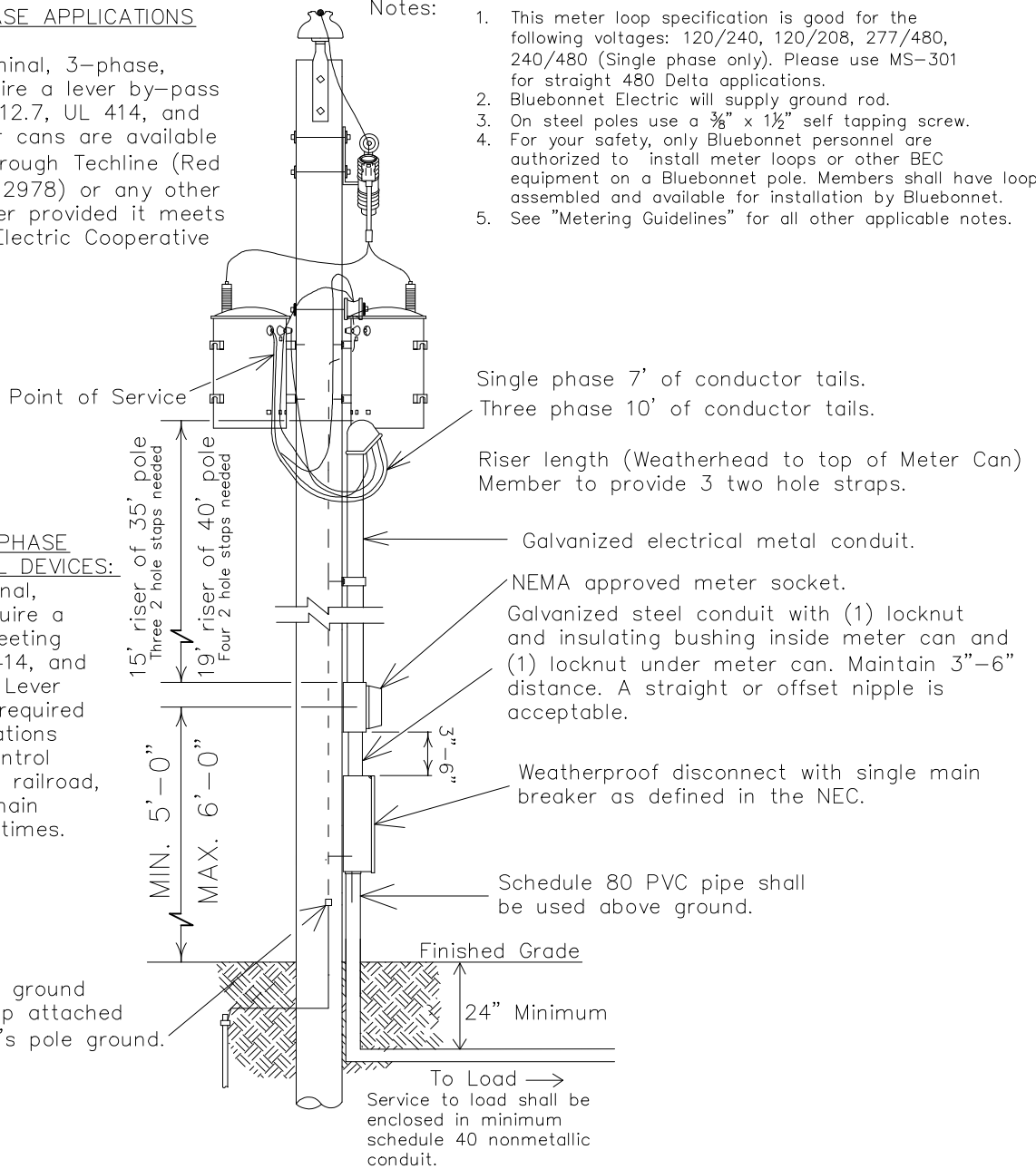

CURRENT CARRYING CAPACITIES AND CONDUIT/NIPPLE SIZE REQUIREMENTS OF STANDARD WIRE SIZES  
(RHH, RHW, THW, THWN, AND XHHW)  
REFER TO NEC FOR OTHER CALCULATIONS.

COPPER CONDUCTOR			ALUMINUM CONDUCTOR		
Wire Size	Breaker Size	Conduit/Nipple Size	Wire Size	Breaker Size	Conduit/Nipple Size
#6	60 Amp	1 1/4" Conduit	#4	60 Amp	1 1/4" Conduit
#4	100 Amp	1 1/4" Conduit	#2	100 Amp	1 1/4" Conduit
#2	125 Amp	1 1/2" Conduit	#1/0	125 Amp	1 1/2" Conduit
#1	150 Amp	2" Conduit	#2/0	150 Amp	2" Conduit
#2/0	200 Amp	2" Conduit	#4/0	200 Amp	2" Conduit

1Ø OR 3Ø 60-200 AMP METER LOOP ON TRANSFORMER POLE



DATE	REVISIONS	Drawn By :	Checked By :	Approved By :
11-27-17	ADDED NIPPLE AFTER CONDUIT SIZE	RG	MS COMMITTEE	MS COMMITTEE
03-18-20	ADDED NOTE 8	Scale :	Date:	
11-04-21	ADDED MAIN BREAKER NOTE	NONE	11-04-2021	MS-102

- Notes:
1. Wire sized to total disconnect size. (See Chart Below)
  2. Reference NEC SEC. 230.9 (A) for meter clearances that state three feet from openings.
  3. Member to provide a secure and reinforced point to connect service attachment.
  4. See "Metering Guidelines" for all other applicable notes.

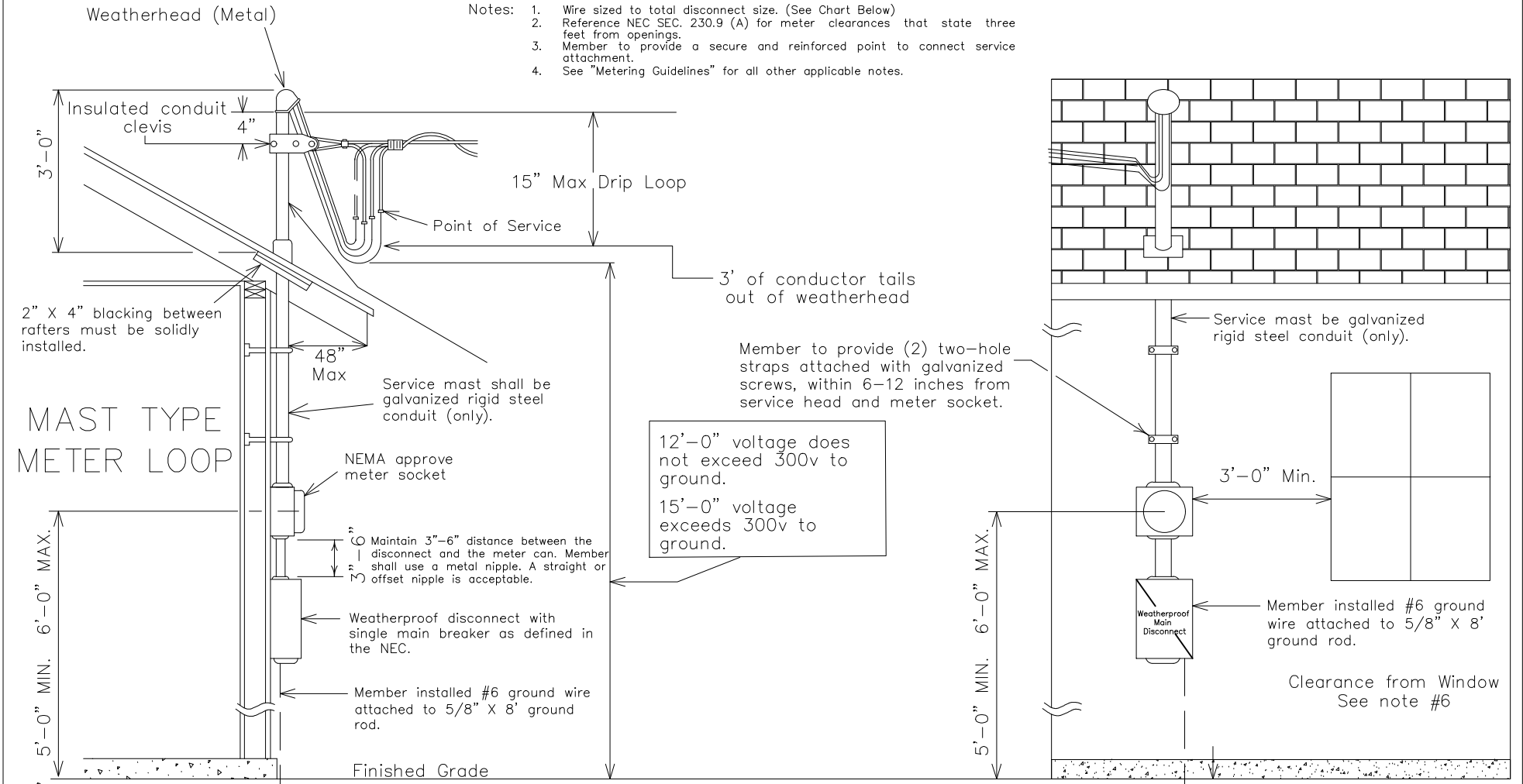

CURRENT CARRYING CAPACITIES AND CONDUIT/NIPPLE SIZE REQUIREMENTS OF STANDARD WIRE SIZES (RH, RHH, RHW, THW, AND XHHW) REFER TO NEC FOR OTHER CALCULATIONS.

COPPER CONDUCTOR			ALUMINUM CONDUCTOR		
Wire Size	Breaker Size	Conduit/Nipple Size	Wire Size	Breaker Size	Conduit/Nipple Size
#6	60 Amp	1 1/2" Conduit	#4	60 Amp	1 1/2" Conduit
#4	100 Amp	1 3/4" Conduit	#2	100 Amp	1 3/4" Conduit
#2	125 Amp	1 3/4" Conduit	#1/0	125 Amp	1 3/4" Conduit
#1	150 Amp	2" Conduit	#2/0	150 Amp	2" Conduit
#2/0	200 Amp	2" Conduit	#4/0	200 Amp	2" Conduit

FOR THREE PHASE APPLICATIONS DESCRIPTION:  
 200amp, 7 terminal, 3-phase, 4-wire will require a lever by-pass meeting ANSI C12.7, UL 414, and NEMA 3R. Meter cans are available for purchase through Techline or any other electrical supplier provided it meets all Bluebonnet Electric Cooperative specifications.



1Ø OR 3Ø 60-200 AMP METER LOOP ON BUILDING, MAST TYPE	
DATE	REVISIONS
11-27-17	ADDED NIPPLE TO CONDUIT SIZE
11-04-21	ADDED MAIN BREAKER NOTE

Drawn By : RG	Checked By : MS COMMITTEE	Approved By : MS COMMITTEE
Scale : NONE	Date: 04-28-2026	MS-103MT

**Notes:**

1. Wire sized to total disconnect size. (See Chart Below)
2. Reference NEC SEC. 230.9 (A) for meter clearances that state three feet from openings.
3. Member to provide a secure and reinforced point to connect service attachment.
4. See "Metering Guidelines" for all other applicable notes.

**FOR THREE PHASE APPLICATIONS**

**DESCRIPTION:**  
 200amp, 7 terminal, 3-phase, 4-wire will require a lever by-pass meeting ANSI C12.7, UL 414, and NEMA 3R. Meter cans are available for purchase through Techline or any other electrical supplier provided it meets all Bluebonnet Electric Cooperative specifications.  
 Techline

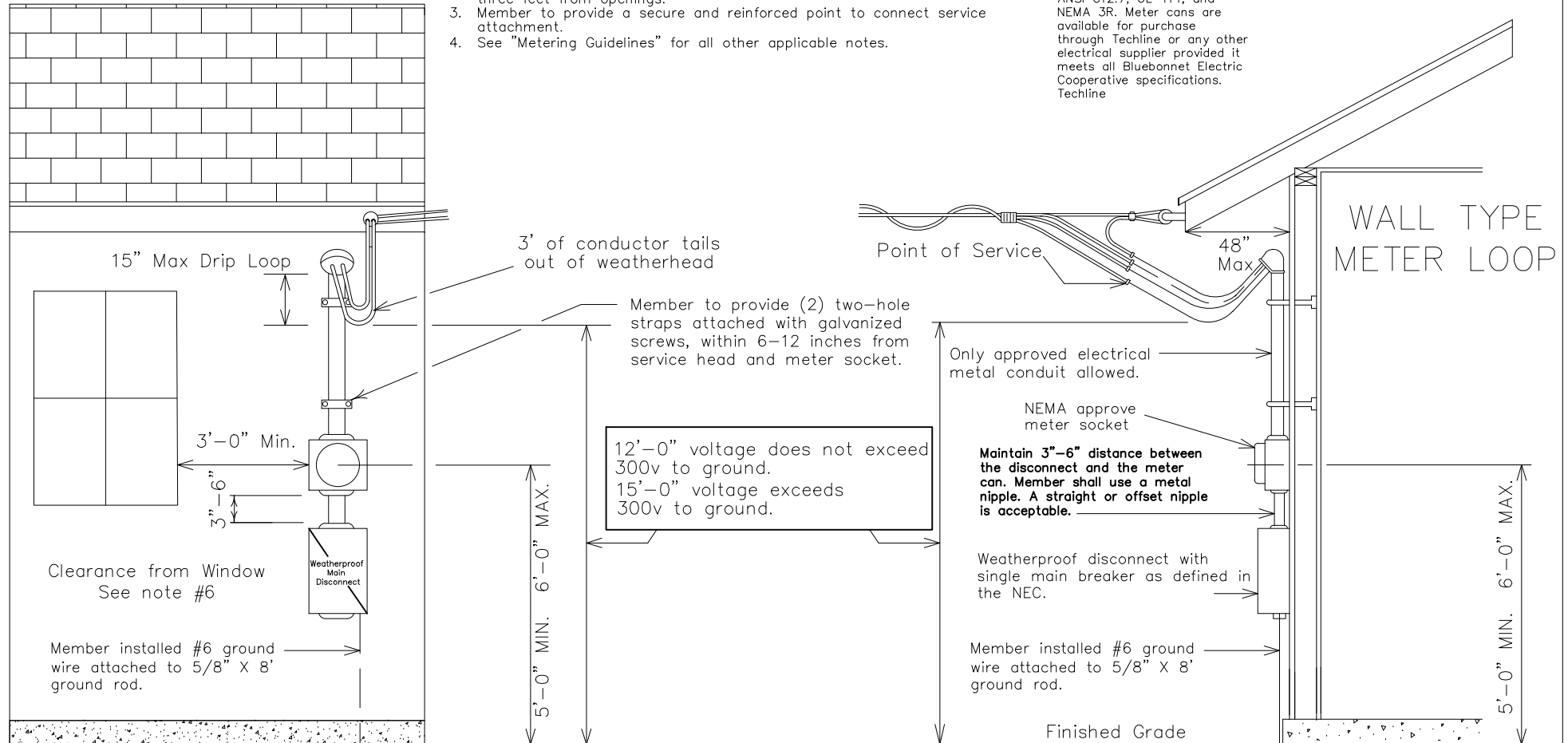

**CURRENT CARRYING CAPACITIES AND CONDUIT/NIPPLE SIZE REQUIREMENTS OF STANDARD WIRE SIZES**  
 (RH, RHH, RHW, THW, AND XHHW)  
 REFER TO NEC FOR OTHER CALCULATIONS.

COPPER CONDUCTOR			ALUMINUM CONDUCTOR		
Wire Size	Breaker Size	Conduit/Nipple Size	Wire Size	Breaker Size	Conduit/Nipple Size
#6	60 Amp	1 1/4" Conduit	#4	60 Amp	1 1/4" Conduit
#4	100 Amp	1 1/2" Conduit	#2	100 Amp	1 1/2" Conduit
#2	125 Amp	1 3/4" Conduit	#1/0	125 Amp	1 3/4" Conduit
#1	150 Amp	2" Conduit	#2/0	150 Amp	2" Conduit
#2/0	200 Amp	2" Conduit	#4/0	200 Amp	2" Conduit



1Ø OR 3Ø 60-200 AMP METER LOOP ON BUILDING, WALL TYPE	
Date	REVISIONS
11-27-17	ADDED NIPPLE TO CONDUIT SIZE
11-04-21	ADDED MAIN BRAKER NOTE

Drawn By :	RG
Scale :	NONE

Checked By :	MS COMMITTEE
Date:	04-28-2026

Approved By :	MS COMMITTEE
	MS-103WT

**Notes:**

- Line taps shall be made in the galvanized trough by the electrical contractor.  
No more than (2) conductors per phase shall be allowed.
- No more than (2) risers will be connected per installation.
- Wire sized to total disconnect sizes. (See Chart Below)
- If secondary service exceeds (2) 2", 3", or 4" approved electrical metal conduit; BEC will install a primary underground transformer at member's expense.
- Maintain 3"-6" distance between the disconnect and the meter can. Member shall use a metal nipple. A straight or offset nipple is acceptable.
- #6 solid, bare ground copper wire and clamp attached to Bluebonnet's pole ground.
- See "Metering Guidelines" for all other applicable notes.

Ⓐ Transformer Pole Riser Length:  
35' Pole = 20' Riser  
40' Pole = 24' Riser

Ⓑ Service Pole Riser Length:  
30' Pole = 20' Riser  
35' Pole = 24' Riser

Ⓒ Member's Conduit  
Member's conduit shall be installed 8"-12" from pole.

**FOR THREE PHASE APPLICATIONS**

**DESCRIPTION:**  
200amp, 7 terminal, 3-phase, 4-wire will require a lever by-pass meeting ANSI C12.7, UL 414, and NEMA 3R. Meter cans are available for purchase through Techline any other electrical supplier provided it meets all Bluebonnet Electric Cooperative specifications. Techline

No more than four 60-200 amp metersockets and weatherproof main disconnects. No more than one disconnect per enclosure.

**RISER ONLY**

Only 2", 3", or 4" approved electrical metal conduct allowed above finished grade. Risers will not exceed 2 risers per pole. Member will provide 10' of conductor tails from top of weatherhead. BEC to supply Stand-Offs. (Bluebonnet to mount risers to pole)

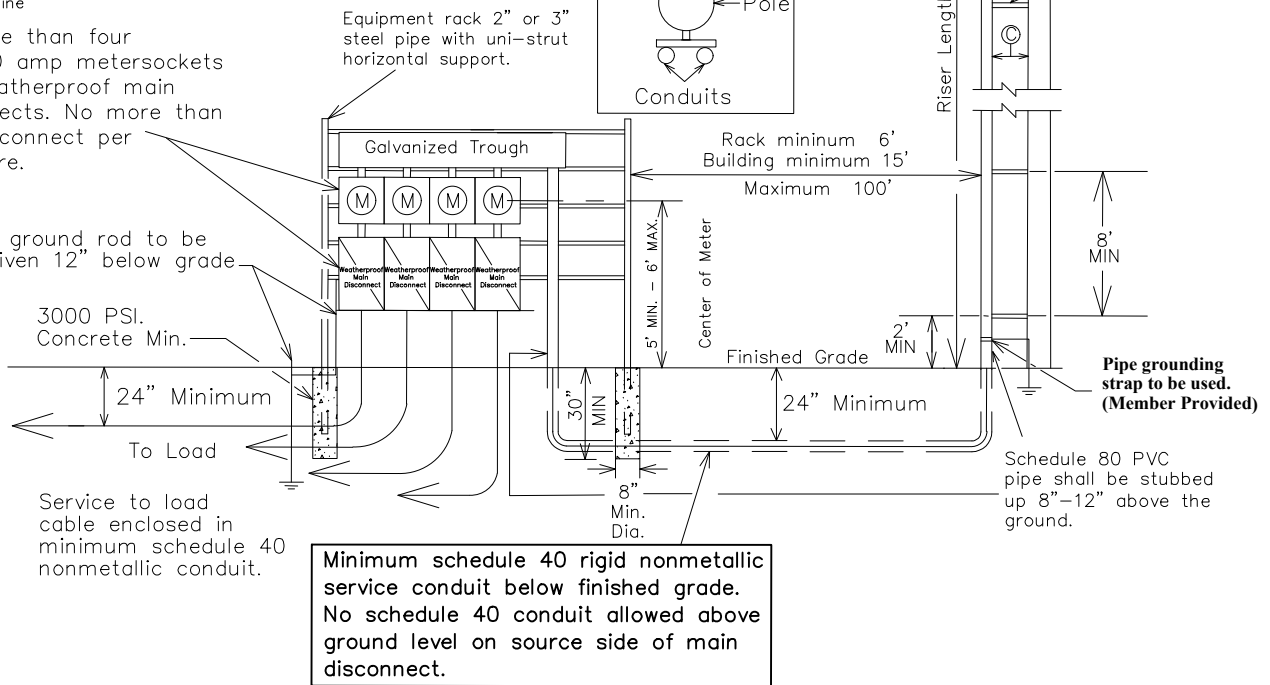
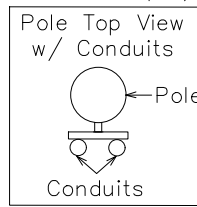

CURRENT CARRYING CAPACITIES AND CONDUIT/NIPPLE SIZE REQUIREMENT OF STANDARD WIRE SIZE. (RHH, RHW, THW, THWN, THHN, AND XHHW) REFER TO NEC FOR OTHER CALCULATIONS.					
WIRE SIZE	COPPER CONDUCTOR/ BREAKER SIZE	CONDUIT/NIPPLE SIZE	WIRE SIZE	ALUMINUM CONDUCTOR BREAKER SIZE	CONDUIT/NIPPLE SIZE
#6	60 AMP	1/4" CONDUIT	#4	60 AMP	1/4" CONDUIT
#4	100 AMP	1/4" CONDUIT	#2	100 AMP	1/4" CONDUIT
#2	125 AMP	1/2" CONDUIT	#1/0	125 AMP	1/2" CONDUIT
#1	150 AMP	2" CONDUIT	#2/0	150 AMP	2" CONDUIT
#2/0	200 AMP	2" CONDUIT	#4/0	200 AMP	2" CONDUIT

1Ø OR 3Ø 60-200 AMP MULTIPLE METERS ON RACK OR BUILDING NOT TO EXCEED A TOTAL OF 800 AMPS



DATE	REVISIONS	Drawn By :	Checked By :	Approved By :
12-07-2017	ADDED WIRE SIZING CHART.	RG	MS COMMITTEE	MS COMMITTEE
11-19-2019	ADDED SOLID COPPER NOTE.	Scale :	Date :	
11-04-2021	ADDED MAIN BREAKER NOTE.	NONE	11-04-2021	MS-105

CURRENT CARRYING CAPACITIES AND CONDUIT/NIPPLE SIZE REQUIREMENT OF STANDARD WIRE SIZE. (RHH, RHW, THW, THWN, THHN, AND XHHW) REFER TO NEC FOR OTHER CALCULATIONS.		
COPPER CONDUCTOR		
WIRE SIZE	BREAKER SIZE	CONDUIT/NIPPLE SIZE
#6	60 AMP	1¼" CONDUIT
#4	100 AMP	1¼" CONDUIT
#2	125 AMP	1½" CONDUIT
#1	150 AMP	2" CONDUIT
#2/0	200 AMP	2" CONDUIT
ALUMINUM CONDUCTOR		
WIRE SIZE	BREAKER SIZE	CONDUIT/NIPPLE SIZE
#4	60 AMP	1¼" CONDUIT
#2	100 AMP	1¼" CONDUIT
#1/0	125 AMP	1½" CONDUIT
#2/0	150 AMP	2" CONDUIT
#4/0	200 AMP	2" CONDUIT

Notes:

- #6 solid, bare ground copper wire and clamp attached to Bluebonnet's pole ground.
- See "Metering Guidelines" for all other applicable notes.

Ⓐ  
Riser Length:  
35' Pole = 20' Riser  
40' Pole = 24' Riser

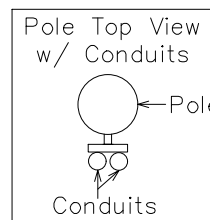

FOR THREE PHASE APPLICATIONS  
DESCRIPTION:

200amp, 7 terminal, 3-phase, 4-wire will require a lever by-pass meeting ANSI C12.7, UL 414, and NEMA 3R. Meter cans are available for purchase through Tecline or any other electrical supplier provided it meets all Bluebonnet Electric Cooperative specifications.

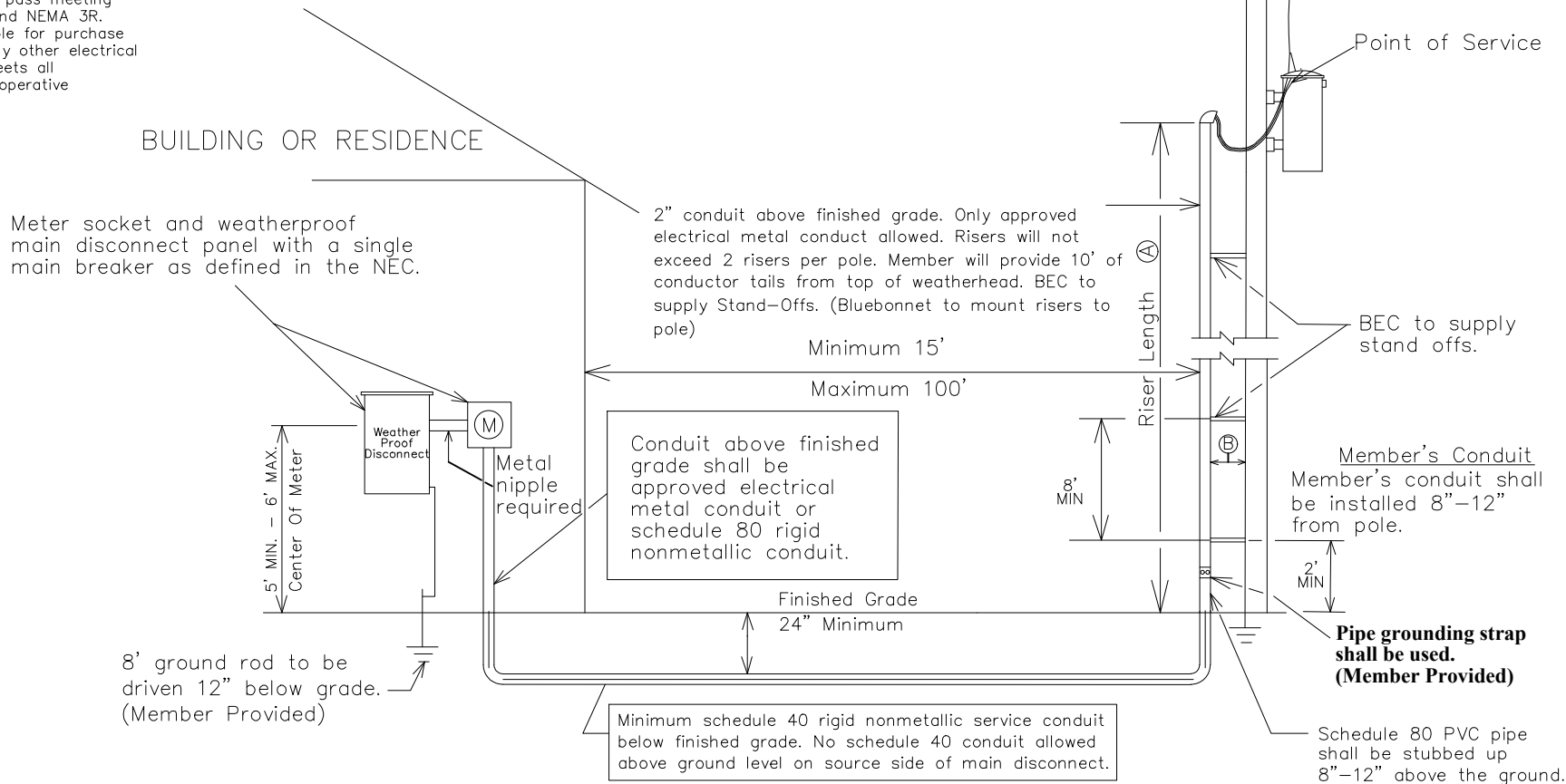

1Ø OR 3Ø 60-200 AMP METER ON BUILDING OR RACK	
DATE	REVISIONS
03-29-2018	MOVED DISCONNECT TO THE SIDE OF METER
11-19-2019	ADDED SOLID COPPER NOTE
11-04-2021	ADDED MAIN BREAKER NOTE

Drawn By : CV
Scale : NONE

Checked By : MS COMMITTEE
Date : 11-04-2021

Approved By : MS COMMITTEE
MS-106

CURRENT CARRYING CAPACITIES AND CONDUIT/NIPPLE SIZE REQUIREMENT OF STANDARD WIRE SIZE. (RHH, RHW, THW, THWN, THHN, AND XHHW) REFER TO NEC FOR OTHER CALCULATIONS.		
COPPER CONDUCTOR		
WIRE SIZE	BREAKER SIZE	CONDUIT/NIPPLE SIZE
#6	60 AMP	1¼" CONDUIT
#4	100 AMP	1¼" CONDUIT
#2	125 AMP	1½" CONDUIT
#1	150 AMP	2" CONDUIT
#2/0	200 AMP	2" CONDUIT
ALUMINUM CONDUCTOR		
WIRE SIZE	BREAKER SIZE	CONDUIT/NIPPLE SIZE
#4	60 AMP	1¼" CONDUIT
#2	100 AMP	1¼" CONDUIT
#1/0	125 AMP	1½" CONDUIT
#2/0	150 AMP	2" CONDUIT
#4/0	200 AMP	2" CONDUIT

Notes:

- #6 solid, bare ground copper wire and clamp attached to Bluebonnet's pole ground.
- See "Metering Guidelines" for all other applicable notes.

Ⓐ  
Riser Length:  
35' Pole = 20' Riser  
40' Pole = 24' Riser

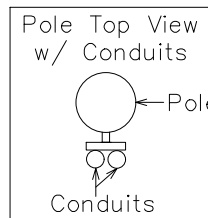

FOR THREE PHASE APPLICATIONS  
DESCRIPTION:

200amp, 7 terminal, 3-phase, 4-wire will require a lever by-pass meeting ANSI C12.7, UL 414, and NEMA 3R. Meter cans are available for purchase through Techline or any other electrical supplier provided it meets all Bluebonnet Electric Cooperative specifications.

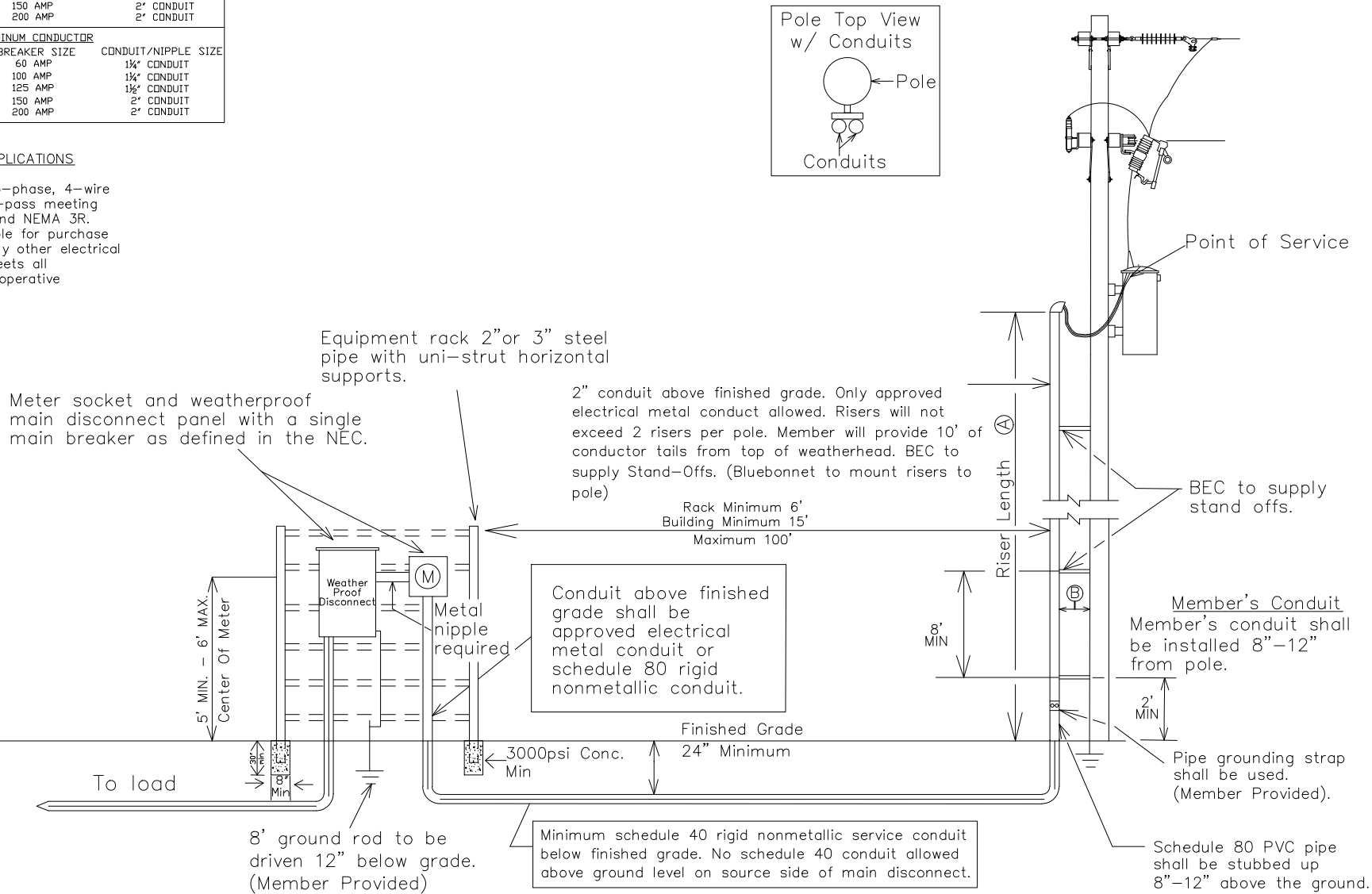

1Ø OR 3Ø 60-200 AMP METER ON RACK	
DATE	REVISIONS
03-29-2018	MOVED DISCONNECT TO THE SIDE OF METER
11-19-2019	ADDED SOLID COPPER NOTE
11-04-2021	ADDED MAIN BREAKER NOTE

Drawn By :	DJ
Scale :	NONE

Checked By :	Engineering
Date :	06-27-2023

Approved By :	Standards
	MS-106A

- Notes:
1. Main disconnect panel may not be used as an electrical race way.
  2. Any combination of six disconnects totaling no more than 400 amp. REF. NEC, SEC. 230.71.
  3. A galvanized trough will have to be used if more than two disconnects are installed. Line taps shall be made by the electrical contractor. Reference NEC SEC. 230.9 (A) for meter clearances that state three feet from opening.
  - 4.
  5. All services entering the meter can from a riser will be top fed.
  6. Only 400 amp meter can is allowed. 320 amp meter cans are not allowed.
  7. A detailed load sheet shall be filled and returned to Bluebonnet before the service will be connected.
  8. No wires shall run in the center of the can. (Due to the clearance needed to set the meter.)

9. Largest wire to be pulled into the meter can is 500 MCM Copper.
10. All service wires entering the meter can (Top or Bottom Feed) will be terminated at the closest lugs. No phase conductors shall be run through the center of the meter can.
11. See "Metering Guidelines" for all other applicable notes.

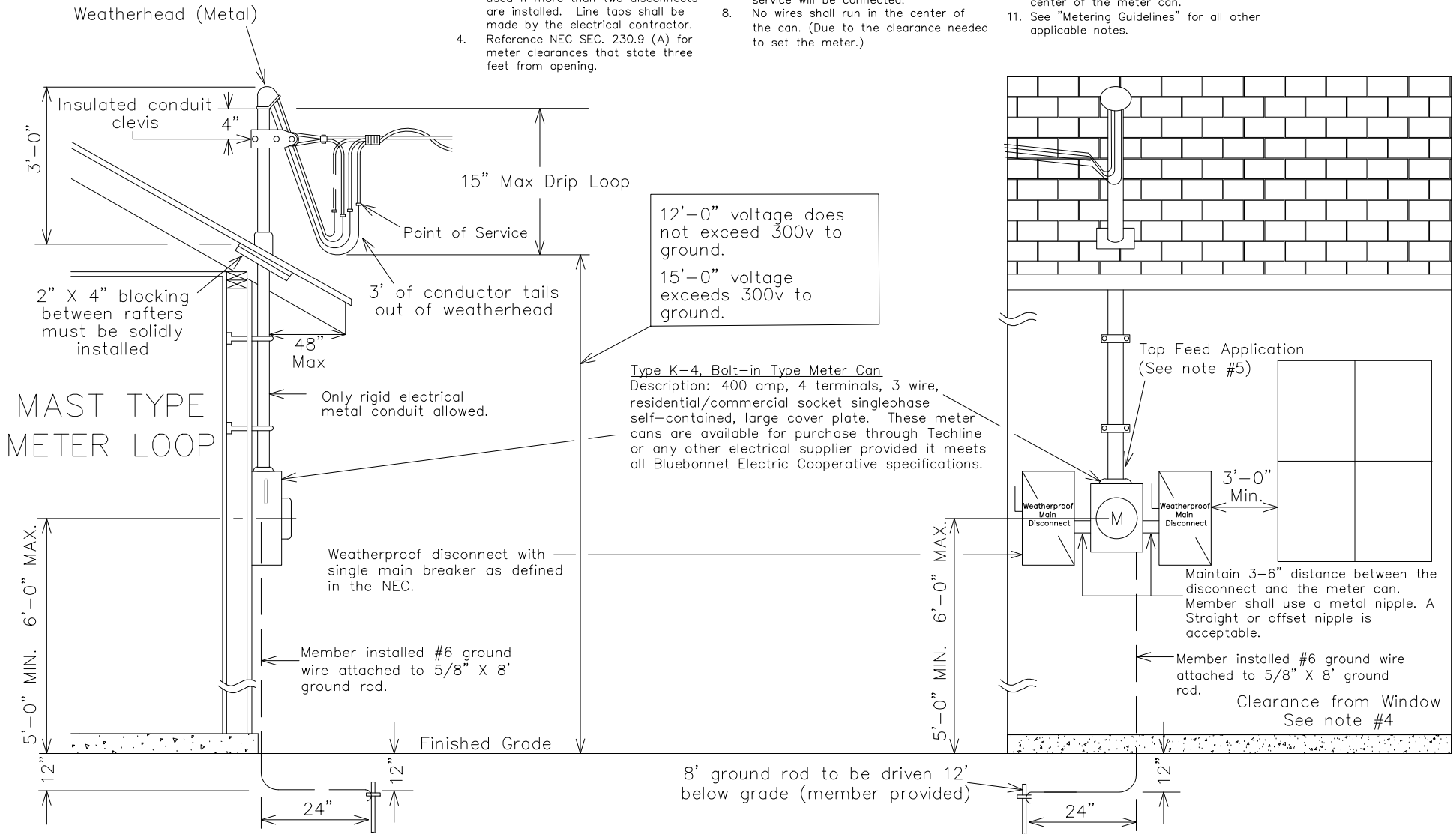

1Ø 400 AMP SERVICE WITH  
METER LOOP ON BUILDING – MAST TYPE

DATE	REVISIONS
11/4/2021	ADDED MAIN BREAKER NOTE

Drawn By :  
BS  
Scale :  
NONE

Checked By :  
MS COMMITTEE  
Date:  
04-28-2026

Approved By :  
MS COMMITTEE  
MS-107MT

- Notes:
1. Main disconnect panel may not be used as an electrical race way. Any combination of six disconnects totaling no more than 400 amp. REF. NEC, SEC. 230.71.
  2. A galvanized trough will have to be used if more than two disconnects are installed. Line taps shall be made by the electrical contractor.
  3. Reference NEC SEC. 230.9 (A) for meter clearances that state three feet from openings.
  4. All services entering the meter can from a riser will be top fed.
  5. Only 400 amp meter can is allowed. 320 amp meter cans are not allowed.
  6. A detailed load sheet shall be filled out and returned to Bluebonnet before this service will be connected.
  7. No wires shall run in the center of the can. (Due to the clearance needed to set the meter.)
  8. Largest wire to be pulled in to the meter can is 500 MCM Copper.
  9. All service wires entering the meter can (Top or Bottom Feed) will be terminated at the closest lugs. No phase conductors shall be run through the center of the meter can.
  10. See "Metering Guidelines" for all other applicable notes.

(A) Type K-4, Bolt-in Type Meter Can  
 Description: 400 amp, 4 terminals, 3 wire, residential/commercial socket singlephase self-contained, large coverplate. These meter cans are available for purchase through Techline or any other electrical supplier provided it meets all Bluebonnet Electric Cooperative specifications.

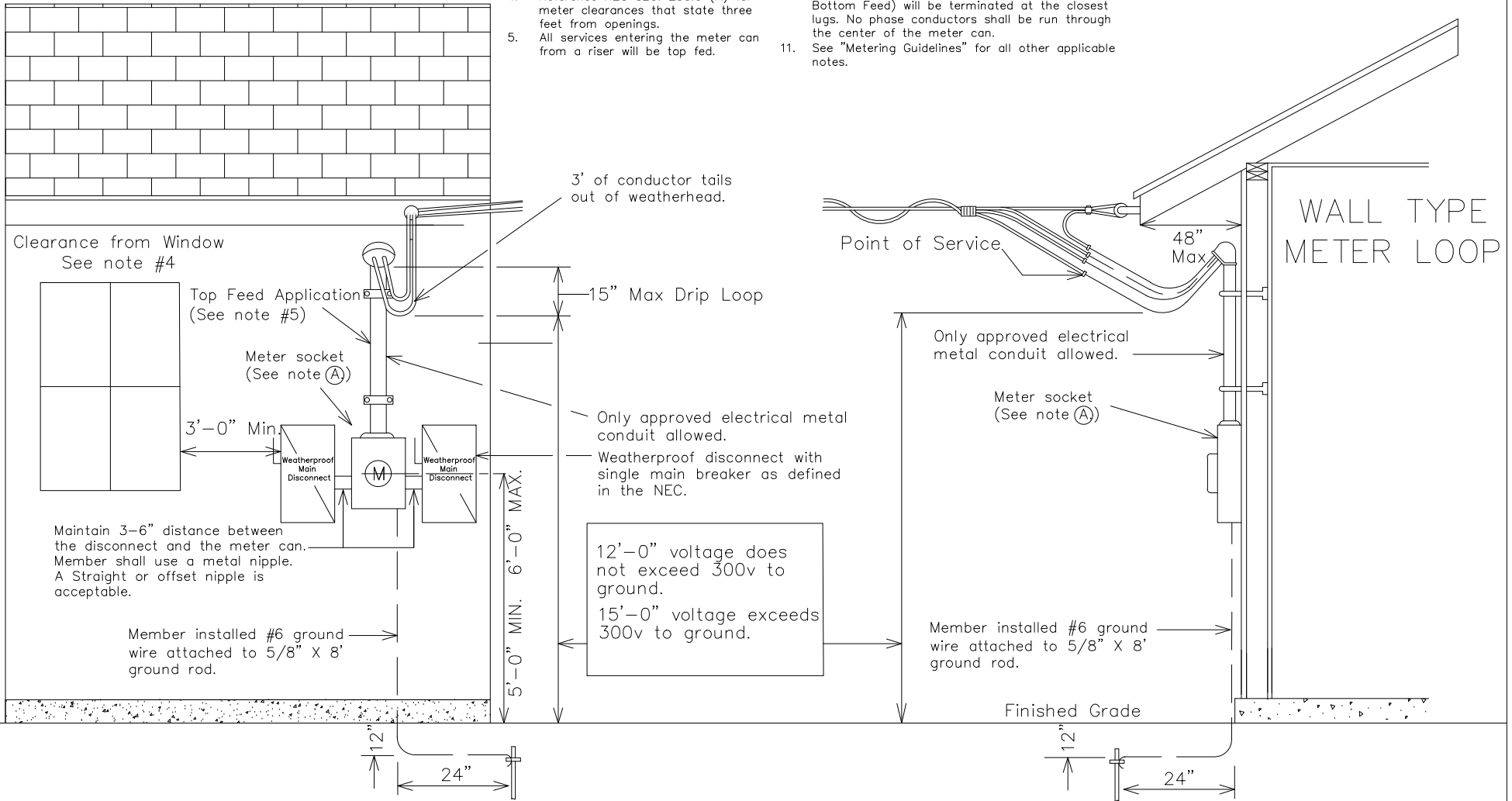

Maintain 3-6" distance between the disconnect and the meter can. Member shall use a metal nipple. A Straight or offset nipple is acceptable.

Member installed #6 ground wire attached to 5/8" X 8' ground rod.

12'-0" voltage does not exceed 300v to ground.  
 15'-0" voltage exceeds 300v to ground.

Member installed #6 ground wire attached to 5/8" X 8' ground rod.



1Ø 400 AMP SERVICE WITH METER LOOP ON BUILDING - WALL TYPE	
DATE	REVISIONS
11-04-2021	Added Main Breaker Note

Drawn By :  
RG  
Scale :  
NONE

Checked By :  
MS COMMITTEE  
Date:  
04-28-2026

Approved By :  
MS COMMITTEE  
MS-107WT

- Notes:
1. Main disconnect panel may not be used as an electrical race way.
  2. Line taps shall be made by the electrical contractor if a galvanized wiring trough is used.
  3. Any combination of six disconnects totaling no more than 400 amp can be used. REF. NEC, SEC. 230.71
  4. If more than two disconnects are needed a galvanized trough is required.
  5. #6 solid, bare ground copper wire and clamp attached to Bluebonnet's pole ground
  6. If secondary service exceeds 1-3" (or 2-2") galvanized metal conduit, BEC will install a primary underground transformer at member's expense.
  7. All service wires entering the meter can (Top or Bottom Feed) will be terminated at the closest lugs. No phase conductors shall be run through the center of the meter can.
  8. Only 400 amp meter cans are allowed. No 320 amp meter cans are allowed.
  9. Member shall use a metal nipple.
  10. Largest wire to be pulled in to the meter can is 500 MCM Copper.
  11. All service wires entering the meter can (Top or Bottom Feed) will be terminated at the closest lugs. No phase conductors shall be run through the center of the meter can.
  12. A detailed load sheet shall be filled out and returned to Bluebonnet before the service will be connected.
  13. Maintain 3"-6" distance between the disconnect and the meter can. Member shall use a metal nipple. A straight or offset nipple is acceptable.
  14. See "Metering Guidelines" for all other applicable notes.

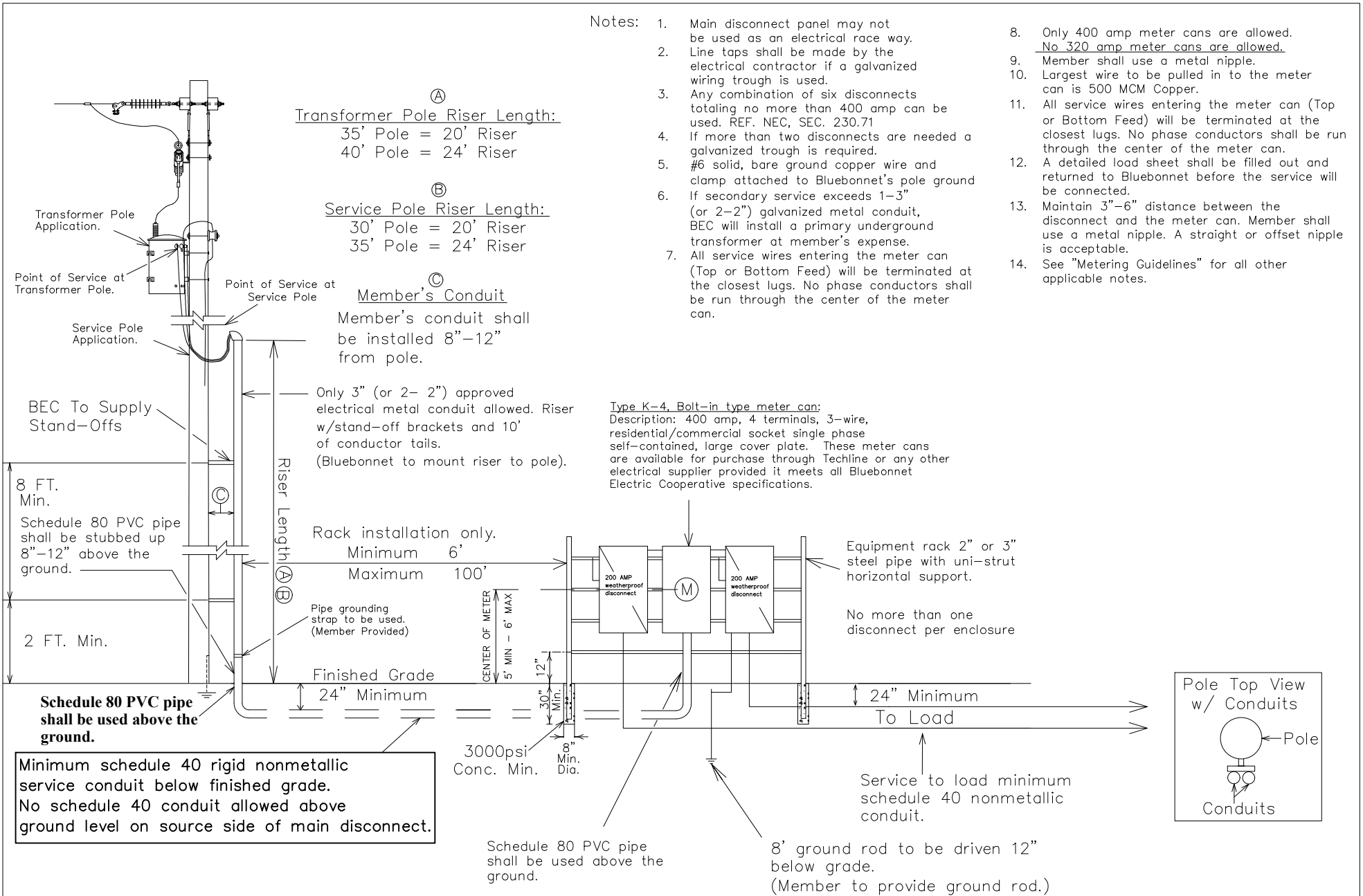

1Ø 400 AMP SERVICE ON METER RACK OR BUILDING WITH K BASE BOLTED IN METER SOCKET		Drawn By : RG	Checked By : MS COMMITTEE	Approved By : MS COMMITTEE
DATE	REVISIONS	Scale :	Date :	
11-19-2019	Added Solid Copper Note	NONE	11-04-2021	MS-108
11-04-2021	Added Main Breaker Note			

Notes:

1. When more than (1) disconnect is used, a galvanized trough system shall be installed.
2. Line taps shall be made in the galvanized wire trough by the electrical contractor. (See Article 310.10 (H) Per NEC).
3. (2) disconnects can be substituted with (1) disconnect. All disconnects shall have over current protection installed.
4. No more than (2) risers or (2) conductors per phase shall be allowed.
5. Bluebonnet to install meter can, meter and current transformers unless there will be multiple metering points from the trough. Contact the support service department on this type of installation.
6. Maintain 3"-6" distance between the disconnect and the meter can. Member shall use a metal nipple. A straight or offset nipple is acceptable.
7. #6 solid, bare ground copper wire and clamp attached to Bluebonnet's pole ground to building ground
8. Total disconnect's will not exceed a total of 800 amps.
9. See "Metering Guidelines" for all other applicable notes.

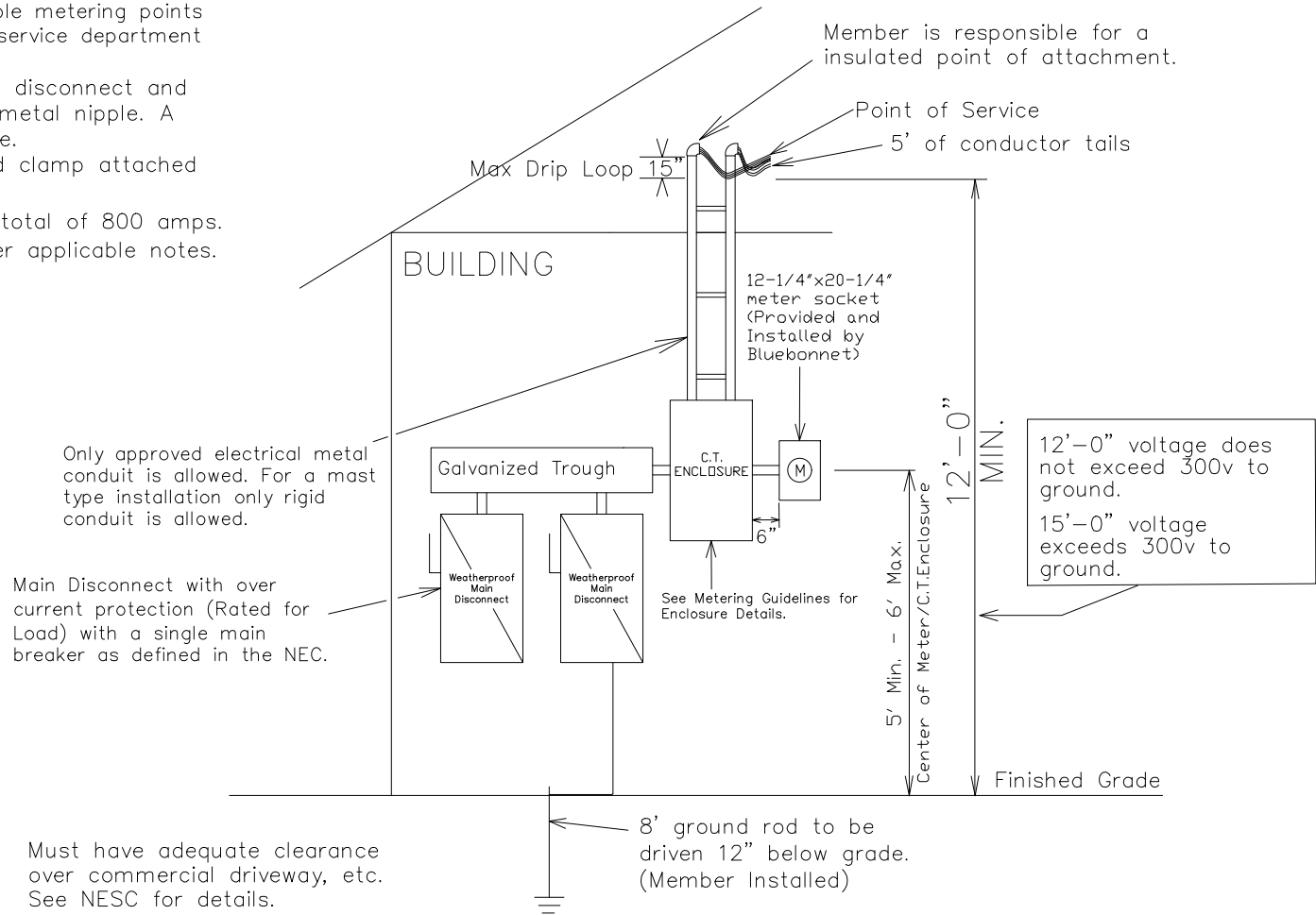

1 PHASE >400-600 AMP SERVICE ON BUILDING WITH CT METERING ON BUILDING OR RACK	
DATE	REVISIONS
11-19-2019	Added #6 copper note.
11-04-2021	Added Main Breaker Note

Drawn By :	RG
Scale :	NONE

Checked By :	MS COMMITTEE
Date :	04-28-2026

Approved By :	MS COMMITTEE
	MS-112B1

Notes:

1. When more than (1) disconnect is used, a galvanized trough system shall be installed.
2. Line taps shall be made in the galvanized wire trough by the electrical contractor. (See Article 310.10 (H) Per NEC).
3. (2) disconnects can be substituted with (1) disconnect. All disconnects shall have over current protection installed.
4. No more than (2) risers or (2) conductors per phase shall be allowed.
5. Bluebonnet to install meter can, meter and current transformers unless there will be multiple metering points from the trough. Contact the support service department on this type of installation.
6. Maintain 3"-6" distance between the disconnect and the meter can. Member shall use a metal nipple. A straight or offset nipple is acceptable.
7. #6 solid, bare ground copper wire and clamp attached to Bluebonnet's pole ground.
8. Total disconnect's will not exceed a total of 800 amps.
9. See "Metering Guidelines" for all other applicable notes.

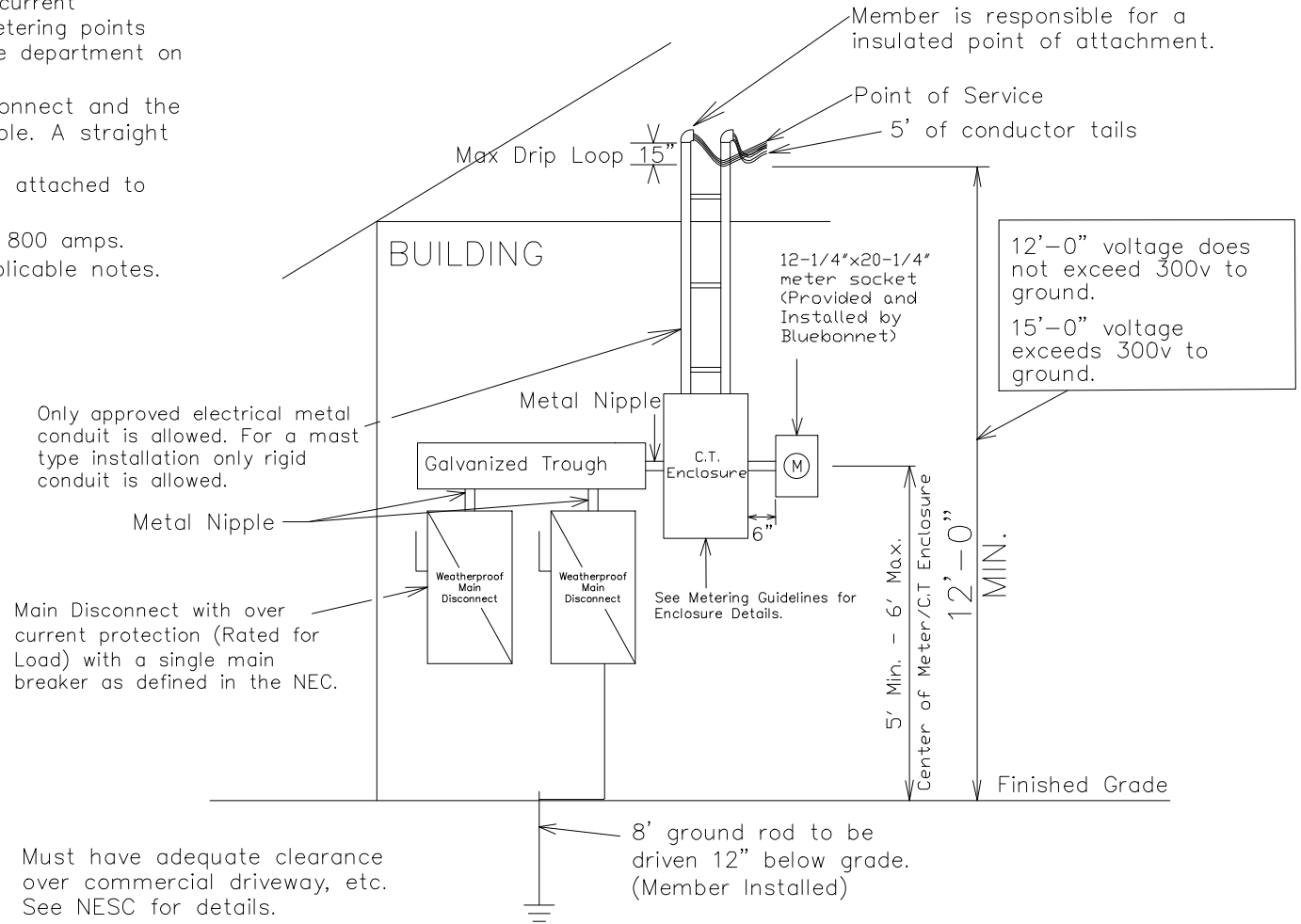

3 PHASE >200-600 AMP SERVICE ON BUILDING WITH CT METERING ON BUILDING OR RACK	
DATE	REVISIONS
11-19-2019	Added solid copper note.
04-16-2021	Removed Single phase from CT enclosure note.
11-04-2021	Added Main Breaker Note

Drawn By :	Checked By :	Approved By :
RG	MS COMMITTEE	MS COMMITTEE
Scale :	Date :	
NONE	04-28-2026	MS-112B3

Notes:

- Line taps shall be made in the galvanized wire trough by the electrical contractor.
- When more than (1) disconnect is used, a galvanized trough system shall be installed.
- Two (2) disconnects could be substituted with (1) disconnect. All disconnects shall have over current protection installed.
- No more than two (2) risers or two (2) conductors per phase shall be allowed.
- Wire shall be sized to total disconnect sizes.
- Maintain 3"-6" distance between the disconnect and the meter can. Member shall use a metal nipple. A straight or offset nipple is acceptable.
- #6 solid, bare ground copper wire and clamp attached to Bluebonnet's pole ground.
- See "Metering Guidelines" for all other applicable notes.

Ⓐ

Transformer Pole Riser Length:  
 35' Pole = 20' Riser  
 40' Pole = 24' Riser

Ⓑ

Service Pole Riser Length:  
 30' Pole = 20' Riser  
 35' Pole = 24' Riser

Ⓒ

Member's Conduit  
 Member's conduit shall be installed 8"-12" from pole

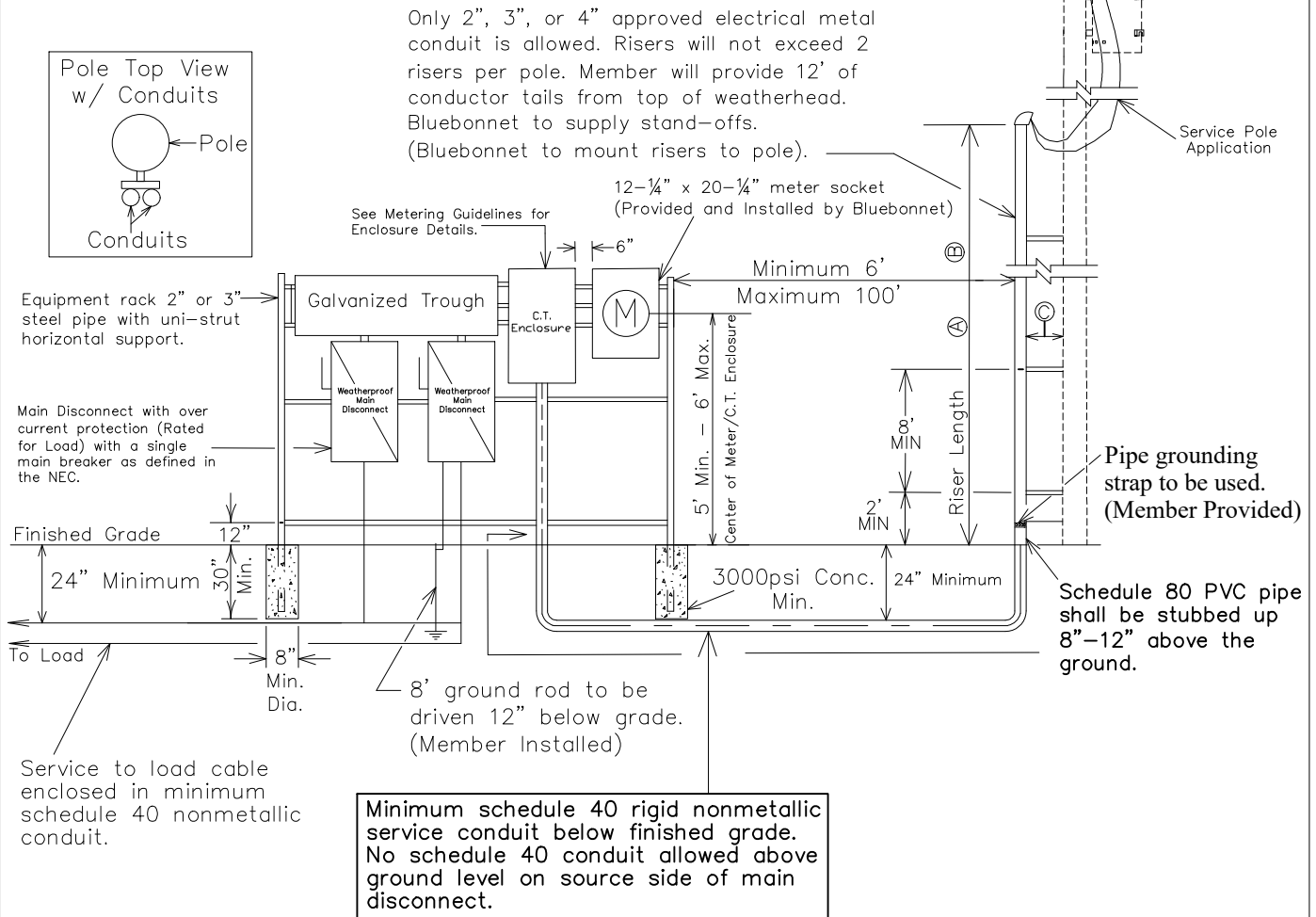

1 PHASE >400-800 AMP SERVICE  
 WITH CT METERING ON RACK



DATE	REVISIONS	Drawn By :	Checked By :	Approved By :
11-28-2017	Bold lettering of schedule 80 PVC	RG	MS COMMITTEE	MS COMMITTEE
11-19-2019	Added Solid Copper Note.			
04-16-2021	Changed the size of the CT Meter Can requirements.	Scale :	DATE:	
11-04-2021	Added Main Breaker Note	NONE	11-04-2021	MS-113B1

**Notes:**

1. Line taps shall be made in the galvanized wire trough by the electrical contractor.
2. When more than (1) disconnect is used, a galvanized rough system shall be installed.
3. Two (2) disconnects could be substituted with (1) disconnect. All disconnects shall have over current protection installed.
4. No more than two (2) risers or two (2) conductors per phase shall be allowed.
5. Maintain 3"-6" distance between the disconnect and the meter can.
6. Member shall use a metal nipple. A straight or offset nipple is acceptable.
7. #6 solid, bare ground copper wire and clamp attached to Bluebonnet's pole ground.
8. See "Metering Guidelines" for all other applicable notes.

Ⓐ Transformer Pole Riser Length:

- 35' Pole = 20' Riser
- 40' Pole = 24' Riser

Ⓑ Service Pole Riser Length:

- 30' Pole = 20' Riser
- 35' Pole = 24' Riser

Ⓒ Member's Conduit  
Member's conduit shall be installed 8"-12" from pole

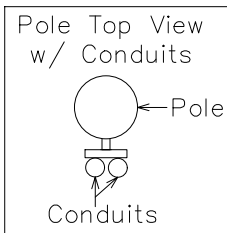
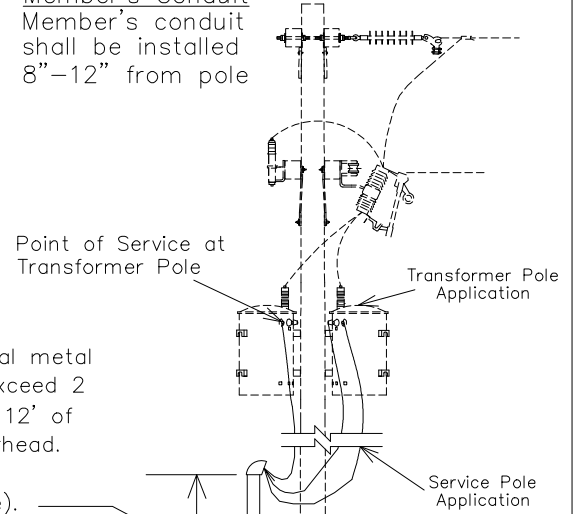

Only 2", 3", or 4" approved electrical metal conduit is allowed. Risers will not exceed 2 risers per pole. Member will provide 12' of conductor tails from top of weatherhead. Bluebonnet to supply stand-offs. (Bluebonnet to mount risers to pole).

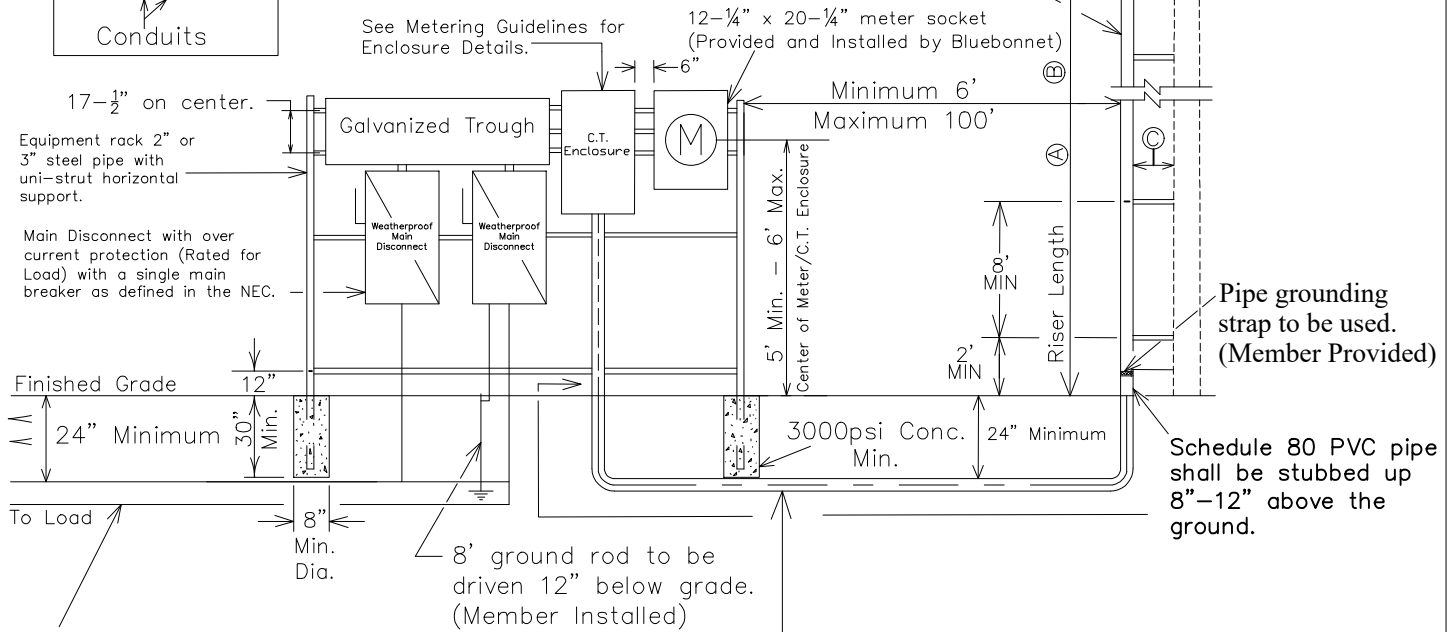

Minimum schedule 40 rigid nonmetallic service conduit below finished grade. No schedule 40 conduit allowed above ground level on source side of main disconnect.

3 PHASE >200-800 AMP SERVICE WITH CT METERING ON RACK



DATE	REVISIONS	Drawn By :	Checked By :	Approved By :
11-28-2017	Bold lettering of schedule 80 PVC	RG	MS COMMITTEE	MS COMMITTEE
11-19-2019	Added Solid Copper Note.			
04-16-2021	Removed Single Phase from the CT Enclosure Note.	Scale :	DATE:	
11-04-2021	Added Main Breaker Note	NONE	11-04-2021	MS-113B3

**Notes:**

- Line taps shall be made in the galvanized wiring trough by the electrical contractor.
- (2) disconnects could be substituted with (1) disconnect. All disconnects shall have over current protection installed.
- No more than (2) risers or (2) conductors per phase shall be allowed.
- More than (6) main disconnects require a properly sized main disconnect ahead of the galvanized trough.
- Type K-4, Bolt-in type meter can: Description: 400 amp, 4 terminals, 3-wire, residential/commercial socket single phase self-contained, large cover plate. These meter cans are available for purchase through Techline or any other electrical supplier provided it meets all Bluebonnet Electric Cooperative specifications.
- Maintain 3"-6" distance from the disconnect and the meter can. Member shall use a metal nipple.
- See "Metering Guidelines" for all other applicable notes.

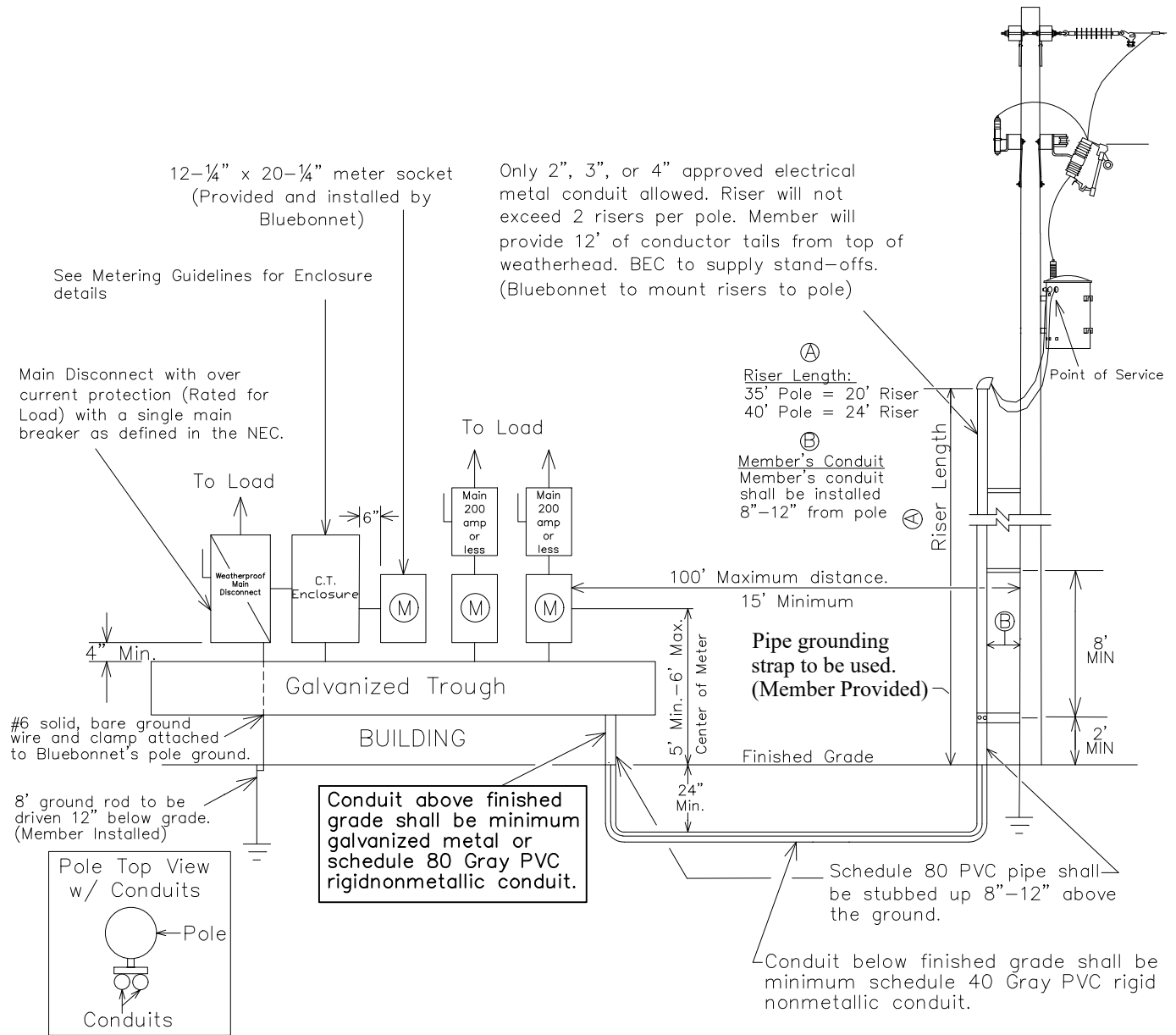

1Ø 400-800 TOTAL AMPS WITH MULTIPLE METERING POINTS ON BUILDING. (RISER TYPE)



DATE	REVISIONS
11-28-2017	Bold lettering of Pipe grounding Strap
11-19-2019	Added Solid Copper Note.
04-19-2021	Changed the size of the CT Meter Can requirements.
11-04-2021	Added Main Breaker Note

Drawn By : RG	Checked By : MS COMMITTEE	Approved By : MS COMMITTEE
Scale : NONE	Date : 11-04-2021	MS-114A1



Notes:

1. When more than (1) disconnect is used, a galvanized trough system shall be installed.
2. Line taps shall be made in the galvanized wire trough by the electrical contractor.
3. (2) disconnects can be substituted with (1) fused disconnect.
4. No more than (2) risers or (2) conductors per phase shall be allowed.
5. Total disconnets will not exceed a total of 800 amps.
6. Gutter can be mounted on top or bottom of meters as long as the center of the meter distance in 5'-6".
7. Maintain 3"-6" distance between the disconnect and the meter can. Member shall use a metal nipple. A straight or offset nipple is acceptable.
8. #6 solid, bare ground copper wire and clamp attached to Bluebonnet's pole ground.
9. No more than one disconnect per enclosure.
10. Type K-4, Bolt-in type meter can:  
Description: 400 amp, 4 terminals, 3-wire, residential/commercial socket singlephase self-contained, large coverplate. These meter cans are available for purchase through Techline or any other electrical supplier provided it meets all Bluebonnet Electric Cooperative specifications.
11. See "Metering Guidelines" for all other applicable notes.

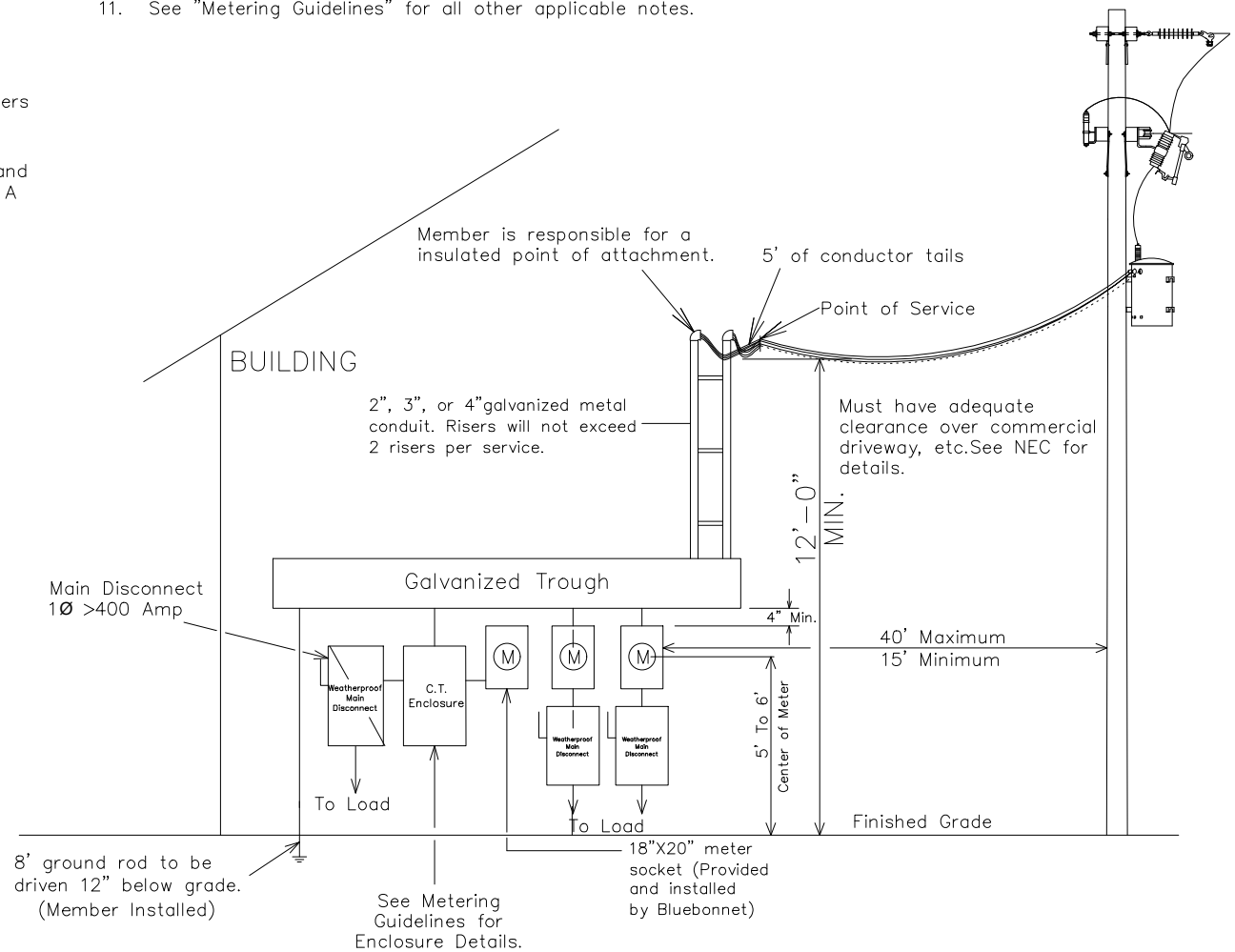

1Ø 400-800 TOTAL AMP WITH MULTIPLE METERING POINTS ON BUILDING. SERVICE TYPE		Drawn By :	Checked By :	Approved By :
		SF	MS COMMITTEE	MS COMMITTEE
DATE	REVISIONS	Scale :	Date :	
04-19-2021	Changed the size of the CT Meter Can requirements.	NONE	11-04-2021	MS-115-1
11-04-2021	Added Main Breaker Note			

Notes:

1. When more than (1) disconnect is used, a galvanized trough system shall be installed.
2. Line taps shall be made in the galvanized wire trough by the electrical contractor.
3. (2) disconnects can be substituted with (1) fused disconnect.
4. No more than (2) risers or (2) conductors per phase shall be allowed.
5. Total disconnect's will not exceed a total of 800 amps.
6. Gutter can be mounted on top or bottom of meters as long as the center of the meter distance in 5'-6".
7. Maintain 3"-6" distance between the disconnect and the meter can. Member shall use a metal nipple. A straight or offset nipple is acceptable.
8. #6 solid, bare ground copper wire and clamp attached to Bluebonnet's pole ground.
9. No more then one Disconnect per enclosure.
10. Type K-4, Bolt-in type meter can:  
Description: 400 amp, 4 terminals, 3-wire, residential/commercial socket singlephase self-contained, large coverplate. These meter cans are available for purchase through Techline or any other electrical supplier provided it meets all Bluebonnet Electric Cooperative specifications.
11. See "Metering Guidelines" for all other applicable notes.

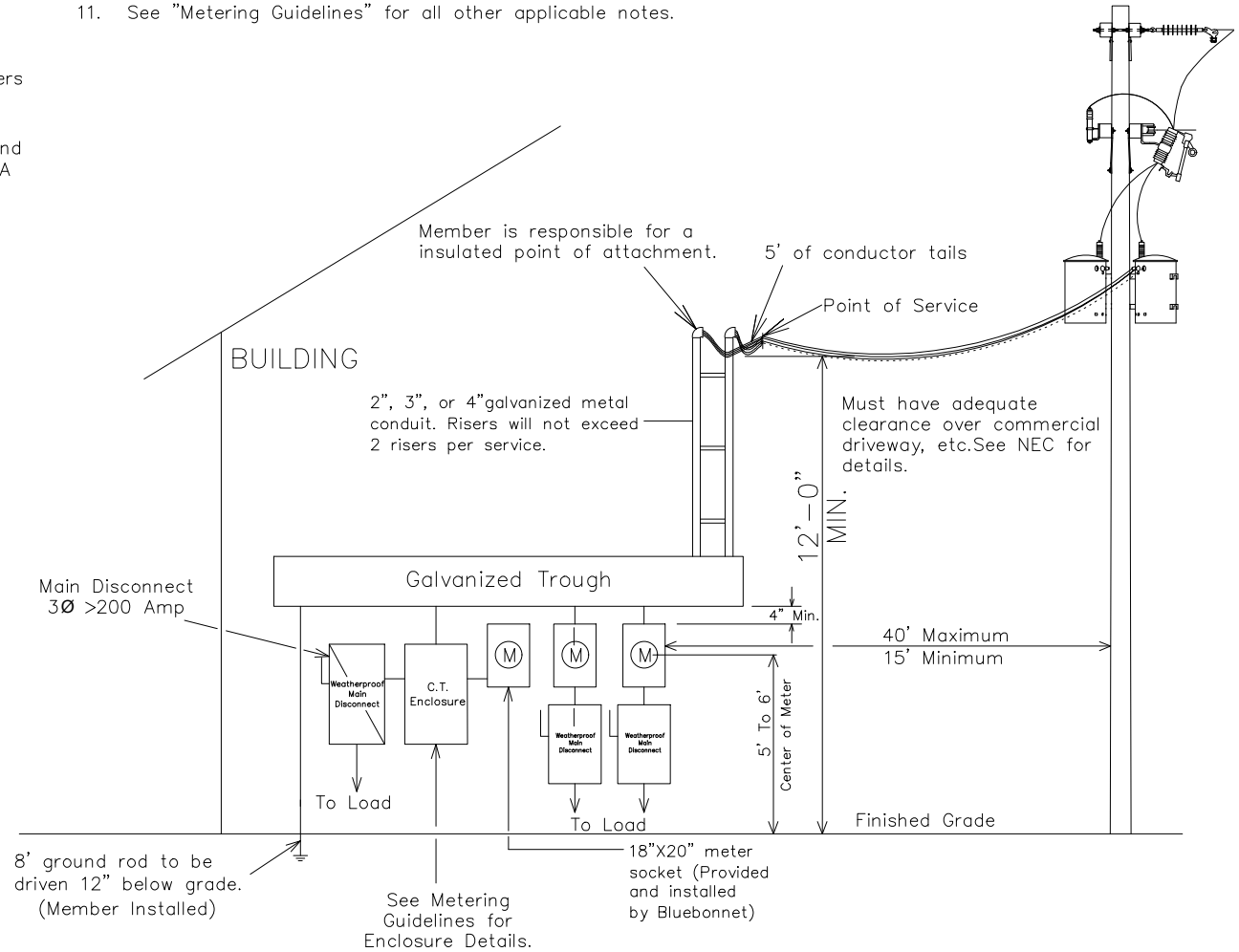

3Ø 200-800 TOTAL AMP WITH MULTIPLE METERING POINTS ON BUILDING. SERVICE TYPE		Drawn By :	Checked By :	Approved By :
		SD	MS COMMITTEE	MS COMMITTEE
DATE	REVISIONS	Scale :	Date :	
04-19-2021	Removed Single Phase from the CT Enclosure Note.	NONE	11-04-2021	MS-115-3
11-04-2021	Added Main Breaker Note			

CURRENT CARRYING CAPACITIES AND CONDUIT/NIPPLE SIZE REQUIREMENT OF STANDARD WIRE SIZE. (RHH, RHW, THW, THWN, THHN, AND XHHW) REFER TO NEC FOR OTHER CALCULATIONS.		
COPPER CONDUCTOR		
WIRE SIZE	BREAKER SIZE	CONDUIT/NIPPLE SIZE
#6	60 AMP	1¼" CONDUIT
#4	100 AMP	1¼" CONDUIT
#2	125 AMP	1½" CONDUIT
#1	150 AMP	2" CONDUIT
#2/0	200 AMP	2" CONDUIT
ALUMINUM CONDUCTOR		
WIRE SIZE	BREAKER SIZE	CONDUIT/NIPPLE SIZE
#4	60 AMP	1¼" CONDUIT
#2	100 AMP	1¼" CONDUIT
#1/0	125 AMP	1½" CONDUIT
#2/0	150 AMP	2" CONDUIT
#4/0	200 AMP	2" CONDUIT

Single Phase Transformer Layout

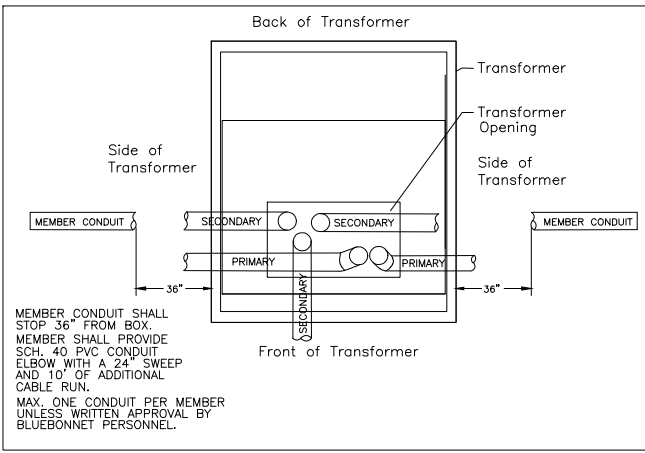

Notes:

- Members shall install an additional 10' of wire for termination.
- Main disconnect shall have a single main breaker as defined in the NEC.
- All connections inside pad mounted transformer and UJB's will be made by Bluebonnet.
- THREE PHASE APPLICATIONS ONLY DESCRIPTION:  
200amp, 7 terminal, 3-phase, 4-wire will require a lever by-pass meeting ANSI C12.7, UL 414, and NEMA 3R. Meter cans are available for purchase through Techline or any other electrical supplier provided it meets all Bluebonnet Electric Cooperative specifications.
- Member must contact Bluebonnet to determine where the secondary conduit is to be run to the transformer. Conduit to be installed 36" to the side of transformer. Call 800-842-7708 to schedule an appointment.
- Member/Electrician shall coordinate with Bluebonnet personal to install all conduit and the pulling of the secondary wire to the transformer. Member/Electrician shall notify Bluebonnet 48 hours in advance to schedule a time/date to perform the work.
- If additional trips are made to the site by Bluebonnet personnel, applicable fees maybe applied.
- See "Metering Guidelines" for other applicable notes.

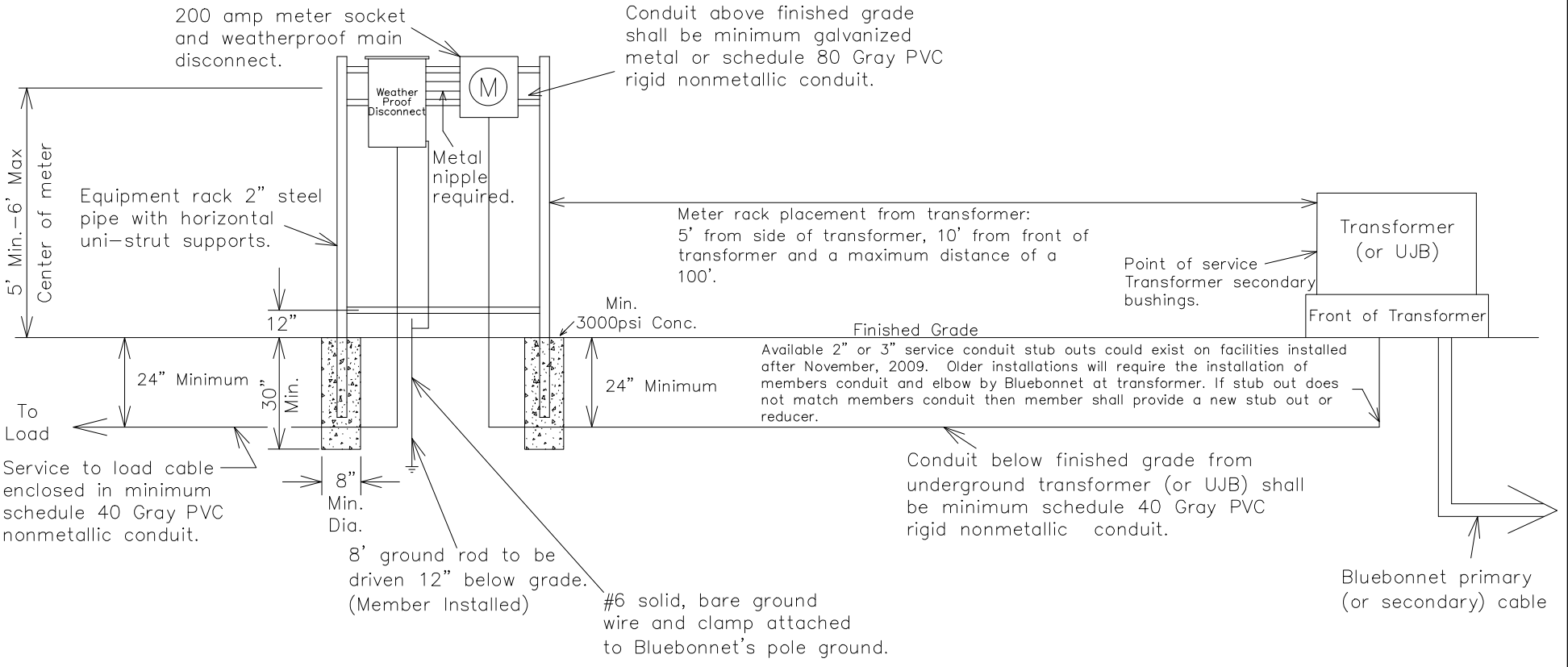

1Ø OR 3Ø, 60-200 AMP UNDERGROUND SERVICE ON RACK OR BUILDING	
DATE	REVISIONS
11-19-2019	ADDED SOLID COPPER NOTE.
11-04-2021	ADDED MAIN BREAKER NOTE.

Drawn By : CV	Checked By : MS COMMITTEE	Approved By : MS COMMITTEE
Scale : NONE	Date : 11-04-2021	MS-201

See Metering Guidelines for Enclosure Details.

12-1/4" x 20-1/4" meter socket (Provided and installed by Bluebonnet)

Main Disconnect with over current protection (Rated for Load) with a single main breaker as defined in the NEC. No more than one disconnect per enclosure.

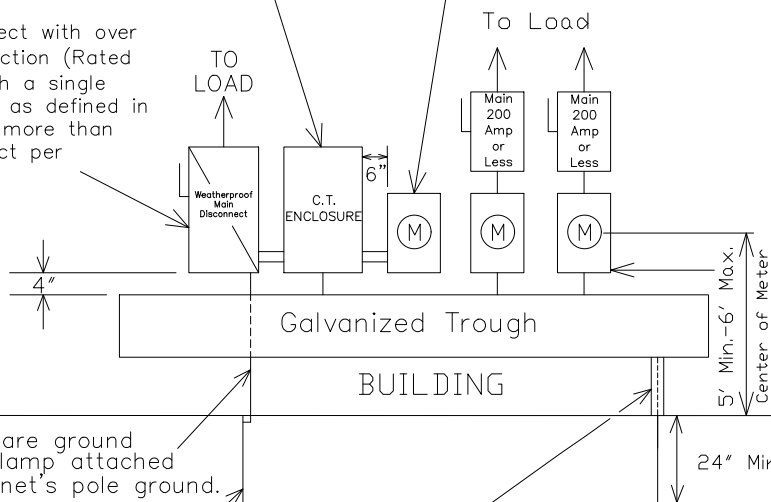

#6 solid, bare ground wire and clamp attached to Bluebonnet's pole ground.

8' ground rod to be driven 12" below grade. (MEMBER INSTALLED)

Conduit above finished grade shall be minimum galvanized metal or schedule 80 Gray PVC rigid nonmetallic conduit.

Conduit below finished grade from underground transformer shall be minimum schedule 40 Gray PVC rigid nonmetallic conduit.

Notes:

- Line taps shall be made in the galvanized wiring trough by the electrical contractor.
- Cooperative will complete wiring into transformer. Have an additional 10' of wire for termination.
- More than (6) main disconnects require a properly sized main disconnect ahead of the galvanized trough.
- All connections inside pad mounted transformer will be made by Bluebonnet.
- THREE PHASE APPLICATIONS ONLY DESCRIPTION:  
200amp, 7 terminal, 3-phase, 4-wire will require a lever by-pass meeting ANSI C12.7, UL 414, and NEMA 3R. Meter cans are available for purchase through Techline or any other electrical supplier provided it meets all Bluebonnet Electric Cooperative specifications. Techline (512-332-2978).
- Member/Electrician shall coordinate with Bluebonnet personal to install all conduit and the pulling of the secondary wire to the transformer. Member/Electrician shall notify Bluebonnet 48 hours in advance to schedule a time/date to perform the work. be applied.
- If additional trips are made to the site by Bluebonnet personnel, applicable fees may be applied.
- Maintain 3"-6" distance between the disconnect and the meter can. Member shall use a metal nipple. A straight or offset nipple is acceptable.
- See "Metering Guidelines" for other applicable notes.

100' maximum distance.

6' minimum distance from side & 10' minimum distance from front of transformer.

Non-combustible walls = 5 feet  
Combustible walls: 0 to 75kVA = 10 feet  
>75kVA = 20 feet

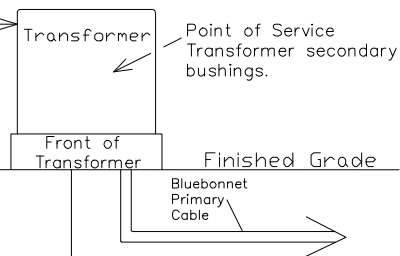

1 PHASE >400 AMP UNDERGROUND WITH MULTIPLE METERING POINTS AND CT METERING ON BUILDING.		Drawn By : RG	Checked By : MS COMMITTEE	Approved By : MS COMMITTEE
DATE	REVISIONS	Scale :	Date :	
04-19-2021	Changed the size of the CT Meter Can requirements.	NONE	11-04-2021	MS-202A1
11-04-2021	Added Main Breaker Note			

Notes:

1. Line taps shall be made in the galvanized wiring trough by the electrical contractor.
2. Cooperative will complete wiring into transformer. Have an additional 10' of wire for termination.
3. More than (6) main disconnects require a properly sized main disconnect ahead of the galvanized trough.
4. All connections inside pad mounted transformer will be made by Bluebonnet.
5. THREE PHASE APPLICATIONS ONLY DESCRIPTION:  
200amp, 7 terminal, 3-phase, 4-wire will require a lever by-pass meeting ANSI C12.7, UL 414, and NEMA 3R. Meter cans are available for purchase through Techline or any other electrical supplier provided it meets all Bluebonnet Electric Cooperative specifications.
6. Member/Electrician shall coordinate with Bluebonnet personal to install all conduit and the pulling of the secondary wire to the transformer. Member/Electrician shall notify Bluebonnet 48 hours in advance to schedule a time/date to perform the work.
7. If additional trips are made to the site by Bluebonnet personnel, applicable fees may be applied.
8. Maintain 3"-6" distance between the disconnect and the meter can. Member shall use a metal nipple. A straight or offset nipple is acceptable.
9. See "Metering Guidelines" for other applicable notes.

See Metering Guidelines for Enclosure Details.

12-1/4" x 20-1/4" meter socket (Provided and installed by Bluebonnet).

Main Disconnect with over current protection (Rated for Load) with a single main breaker as defined in the NEC. No more than one disconnect per enclosure.

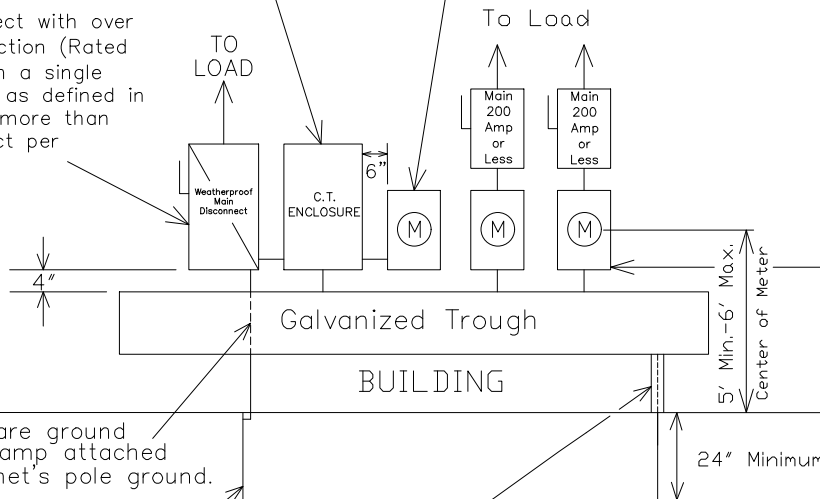

#6 solid, bare ground wire and clamp attached to Bluebonnet's pole ground.

8' ground rod to be driven 12" below grade. (MEMBER INSTALLED)

Conduit above finished grade shall be minimum galvanized metal or schedule 80 Gray PVC rigid nonmetallic conduit.

Conduit below finished grade from underground transformer shall be minimum schedule 40 Gray PVC rigid nonmetallic conduit.

100' maximum distance.

6' minimum distance from side & 10' minimum distance from front of transformer.

Non-combustible walls = 5 feet  
Combustible walls: 0 to 75kVA = 10 feet  
>75kVA = 20 feet

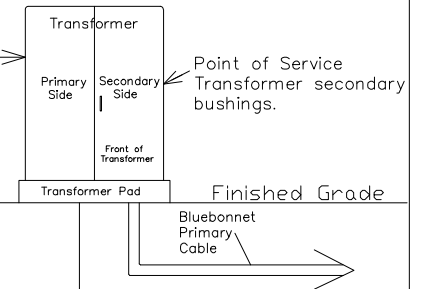

3 PHASE >200 AMP UNDERGROUND WITH MULTIPLE METERING POINTS AND CT METERING ON BUILDING.	
DATE	REVISIONS
04-19-2021	Removed Single Phase from the CT Enclosure Note.
11-04-2021	Added Main Breaker Note

Drawn By :	RG
Scale :	NONE

Checked By :	MS COMMITTEE
Date :	11-04-2021

Approved By :	MS COMMITTEE
	MS-202B3

Notes:

1. Main disconnect panel may not be used as a electrical race way.
2. Line taps shall be made by the electrical contractor if a galvanized wiring trough is used.
3. Any combination of six disconnects totaling no more than 400 amps can be used. REF. NEC, SEC 230.71
4. Recommended wire size is either parallel 2/0 THHN copper or parallel 4/0 THHN aluminum.
5. Member shall install an additional of 10' wire for termination.
6. Weatherproof main disconnect panels shall have a single main breaker or 6-handle main as defined in the NEC.
7. Metering point must remain unenclosed on exterior of structure.
8. All secondary connections in transformer are made by Bluebonnet.
9. Only 400 Amps meter cans are allowed. No 320 Amp Meter Cans are allowed.
10. All service wires entering the meter can (Top or Bottom Feed) will be terminated at the closest lugs. No phase conductors shall be run through the center of the meter can.

11. Member must contact Bluebonnet to determine where the secondary conduit is to be run to the transformer. Conduit to be installed 36" to the side of transformer. Call 800-842-7708 to schedule an appointment.
12. Member/Electrician shall coordinate with Bluebonnet personal to install all conduit and the pulling of the secondary wire to the transformer. Member/Electrician shall notify Bluebonnet 48 hours in advance to schedule a time/date to perform the work.
13. If additional trips are made to the site by Bluebonnet personnel, applicable fees maybe applied.
14. Maintain 3"-6" distance between the disconnect and the meter can. Member shall use a metal nipple. A straight or offset nipple is acceptable.
15. Largest wire to be pulled in to the meter can is 500 MCM Cooper.
16. A detailed load sheet shall be filled out and returned to Bluebonnet before the service will be connected.
17. #6 solid, bare ground copper wire and clamp to Bluebonnet's pole ground.
18. See "Metering Guidelines" for other applicable notes.

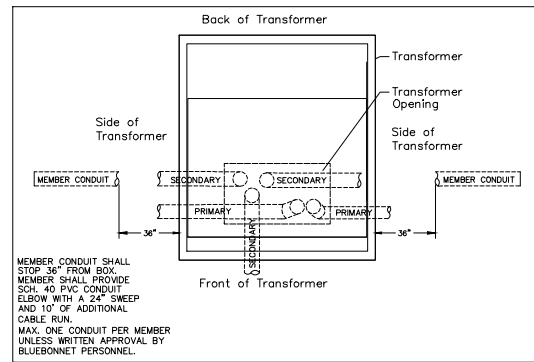

Landis & Gyr, Type K-4, Description: 400 amp, 4 terminals, 3 wire, residential/commercial socket single phase self-contained, large coverplate. The meter lugs can accommodate up to 500 MCM. These meter cans are available for purchase through Techline or any other electrical supplier provided it meets all Bluebonnet Electric Cooperative specifications.

Single Phase Transformer Layout

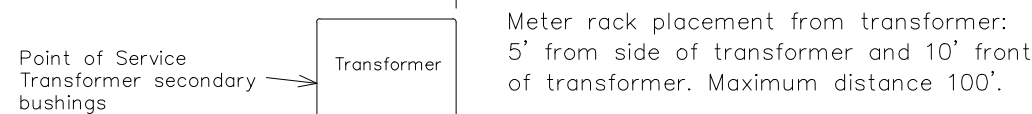

3" Conduit below finished grade from underground transformer to meter shall be minimum schedule 40 Gray PVC rigid nonmetallic conduit.

3" Conduit above finished grade to meter shall be minimum galvanized metal or schedule 80 Gray PVC rigid nonmetallic conduit.

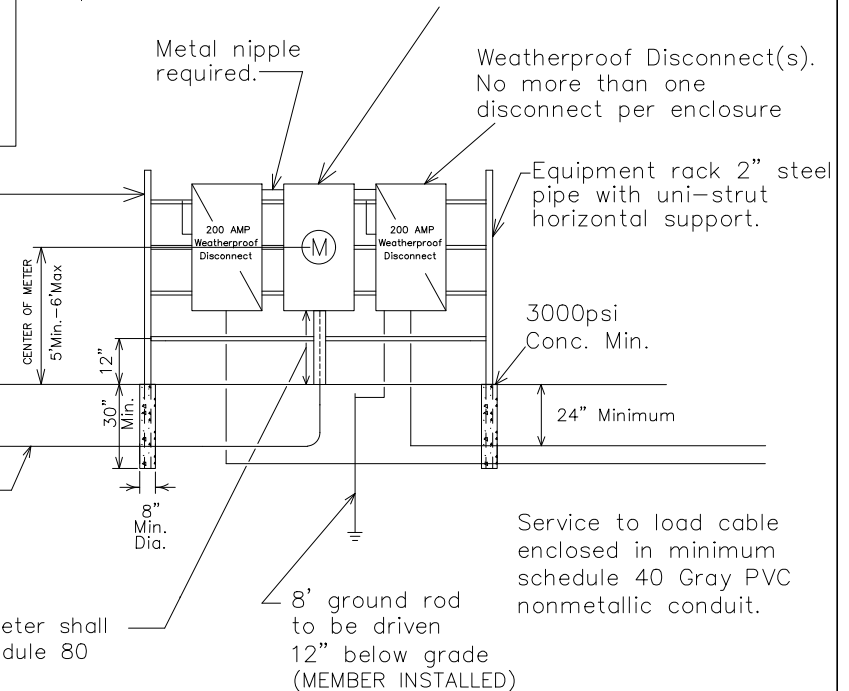

1Ø 400 AMP URD SERVICE ON RACK OR BUILDING WITH K BASE BOLTED IN METER SOCKET		Drawn By : RG	Checked By : MS COMMITTEE	Approved By : MS COMMITTEE
DATE	REVISIONS	Scale :	Date :	
11-20-19	Added Solid Copper Note.	NONE	11-04-2021	MS-203
11-04-21	Added Main Breaker Note			

Notes:

1. Line taps shall be made in the galvanized trough by the electrical contractor.
2. Two disconnects could be substituted with (1) disconnect. All disconnects shall have over current protection.
3. Member shall contact Bluebonnet Electric to determine the secondary conduit location. Conduit to be installed 36" to the side of transformer. Call 800-842-7708 to schedule an appointment.
4. Bluebonnet will complete wiring into transformer. Have sufficient amount of wire for termination. Member shall install an additional 10' of wire for termination
5. Member/Electrician shall coordinate with Bluebonnet personal to install all conduit and the pulling of the secondary wire to the transformer.  
Member/Electrician shall notify Bluebonnet 48 hours in advance to schedule a time/date to perform the work.
6. If additional trips are made to the site by Bluebonnet personnel, applicable fees may be applied.
7. Maintain 3"-6" distance between the disconnect and the meter can.  
Member shall use a metal nipple. A straight or offset nipple is acceptable.
8. See "Metering Guidelines" for other applicable notes.

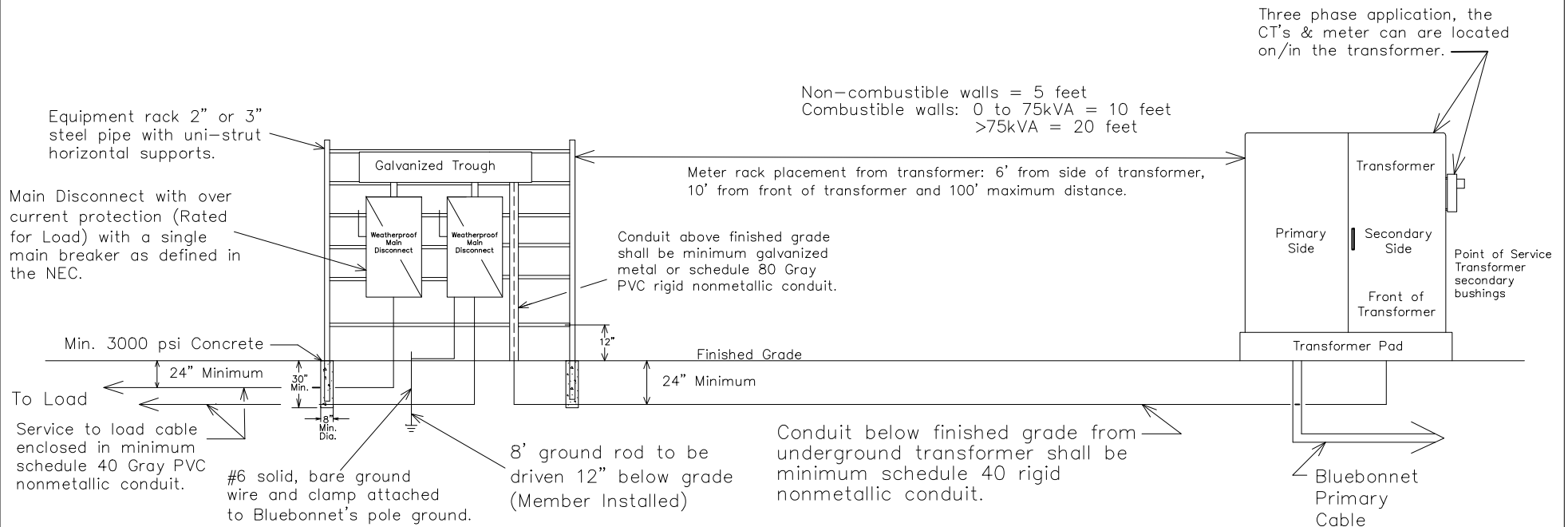

3 PHASE >200 AMP UNDERGROUND SERVICE WITH DISCONNECT ON RACK OR BUILDING

DATE	REVISIONS
11-20-19	Added Solid Copper Note.
11-04-21	Added Main Breaker Note

Drawn By :	RG
Scale :	NONE

Checked By :	MS COMMITTEE
Date :	11-04-2021

Approved By :	MS COMMITTEE
	MS-204A3

Notes:

1. Line taps shall be made in the galvanized wiring trough by the electrical contractor.
2. Wire shall be sized to total name plate disconnect sizes.
3. Cooperative will complete wiring into transformer or UJB. Have an additional 10' of wire for termination.
4. All connections inside pad mounted transformer will be made by Bluebonnet.
5. Member/Electrician shall coordinate with Bluebonnet personal to install all conduit and the pulling of the secondary wire to the transformer. Member/Electrician shall notify Bluebonnet 48 hours in advance to schedule a time/date to perform the work.
6. If additional trips are made to the site by Bluebonnet personnel, applicable fees may be applied.
7. Maintain 3"-6" distance between the disconnect and the meter can. Member shall use a metal nipple. A straight or offset nipple is acceptable.
8. #6 solid, bare ground copper wire and clamp attached to Bluebonnet's pole ground.
9. Max wire size for single-phase underground transformers to be 350 kcmil
10. Limit number of conductors to 4 per phase.
11. See "Metering Guidelines" for other applicable notes.

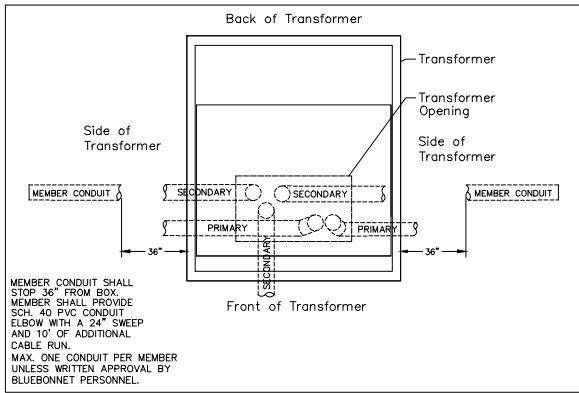

Single Phase Transformer Layout

See Metering Guidelines for Enclosure Details.

Main Disconnect with over current protection (Rated for Load) with a single main breaker as defined in the NEC.

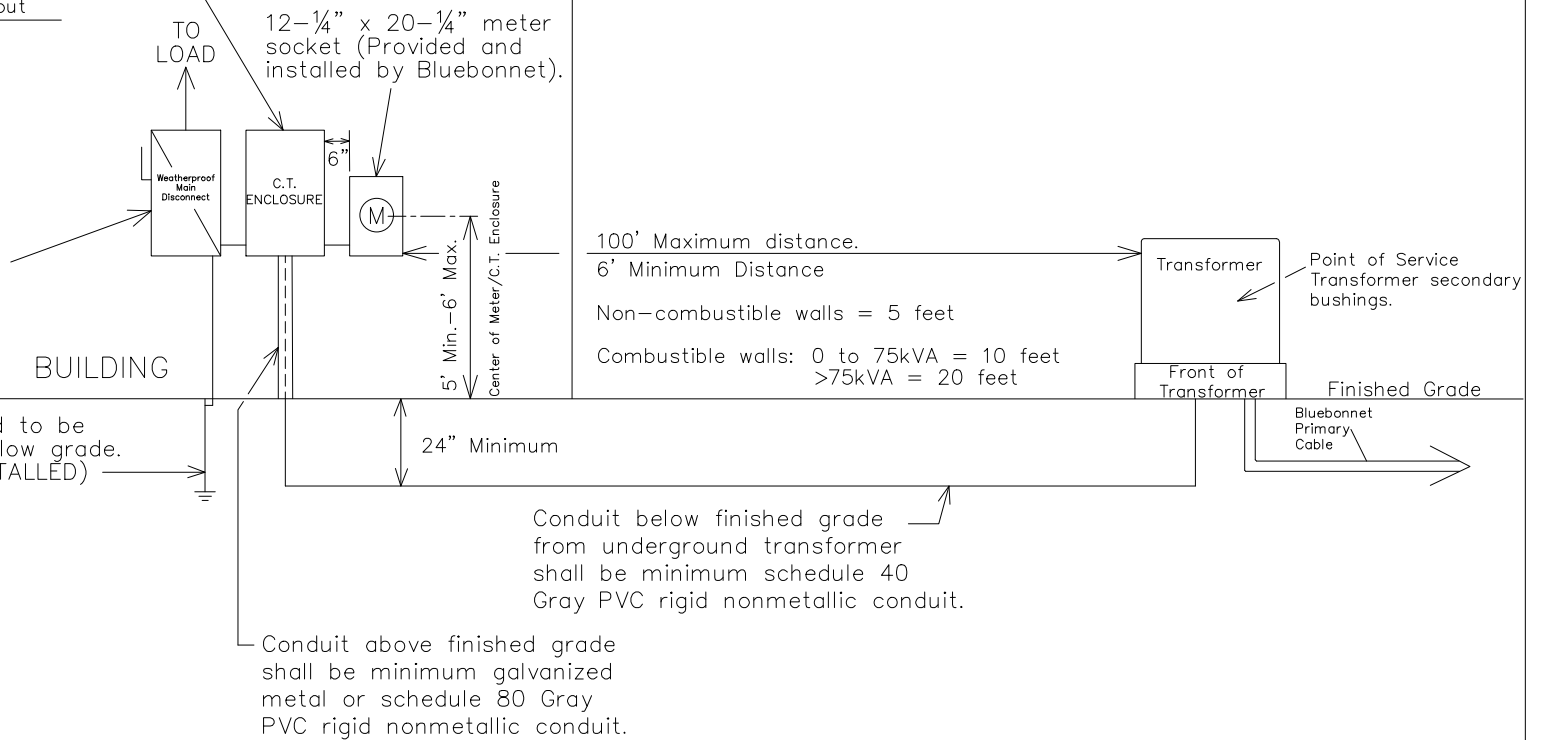

1 PHASE >400 AMP SERVICE WITH CT METERING ON BUILDING OR RACK		Drawn By : RG	Checked By : MS COMMITTEE	Approved By : MS COMMITTEE
11-20-2017	Added Solid Copper Note.	Scale : NONE	Date : 11-04-2021	MS-204B1
04-16-2021	Changed the size of the CT Meter Can requirements.			
11-04-2021	Added Main Breaker Note			

Notes:

1. Line taps shall be made in the galvanized wiring trough by the electrical contractor.
2. Cooperative will complete wiring into transformer or UJB. Have an additional 10' of wire for termination.
3. All connections inside pad mounted transformer will be made by Bluebonnet.
4. Member/Electrician shall coordinate with Bluebonnet personal to install all conduit and the pulling of the secondary wire to the transformer. Member/Electrician shall notify Bluebonnet 48 hours in advance to schedule a time/date to perform the work.
5. If additional trips are made to the site by Bluebonnet personnel, applicable fees may be applied.
6. Maintain 3"-6" distance between the disconnect and the meter can. Member shall use a metal nipple. A straight or offset nipple is acceptable.
7. #6 solid, bare ground copper wire and clamp attached to Bluebonnet's pole ground.
8. Max wire size for single-phase underground transformers to be 350 kcmil
9. Limit number of conductors to 4 per phase.
10. See "Metering Guidelines" for other applicable notes.

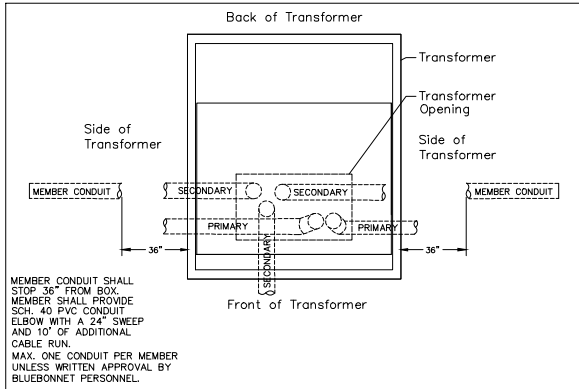

Single Phase Transformer Layout

See Metering Guidelines for Enclosure Details.

12-1/4" x 20-1/4" meter socket (installed by Bluebonnet).

Main Disconnect with over current protection (Rated for Load) with a single main breaker or if no main breaker is used, no more than a 6-handle main as defined in the NEC.

BUILDING

8' ground rod to be driven 12" below grade. (MEMBER INSTALLED)

Conduit above finished grade shall be minimum galvanized metal or schedule 80 Gray PVC rigid nonmetallic conduit.

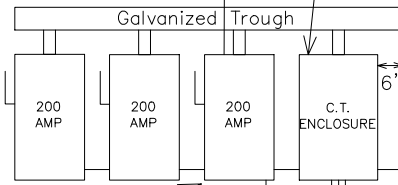

5' Min. - 6' Max. Center of Meter/C.T. Enclosure

100' Maximum distance.  
6' Minimum Distance  
Non-combustible walls = 5 feet  
Combustible walls: 0 to 75kVA = 10 feet  
>75kVA = 20 feet

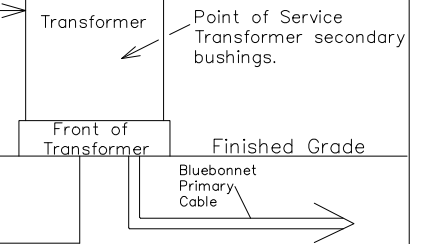

Conduit below finished grade from underground transformer shall be minimum schedule 40 Gray PVC rigid nonmetallic conduit.



1 PHASE >400 AMP SERVICE WITH CT METERING ON BUILDING OR RACK

01-30-2017 Changed the dimensions of the CT Enclosure.  
11-20-2017 Added Solid Copper Note.

Drawn By :  
RG

Scale :  
NONE

Checked By :  
MS COMMITTEE

Date :  
01-30-2017

Approved By :  
TE

MS-204B2

Notes:

1. Line taps shall be made in the galvanized wiring trough by the electrical contractor.
2. Cooperative will complete wiring into transformer or UJB. Have an additional 10' of wire for termination.
3. All connections inside pad mounted transformer will be made by Bluebonnet.
4. Member/Electrician shall coordinate with Bluebonnet personal to install all conduit and the pulling of the secondary wire to the transformer.  
Member/Electrician shall notify Bluebonnet 48 hours in advance to schedule a time/date to perform the work.
5. If additional trips are made to the site by Bluebonnet personnel, applicable fees may be applied.
6. Maintain 3"-6" distance between the disconnect and the meter can. Member shall use a metal nipple. A straight or offset nipple is acceptable.
7. See "Metering Guidelines" for other applicable notes.

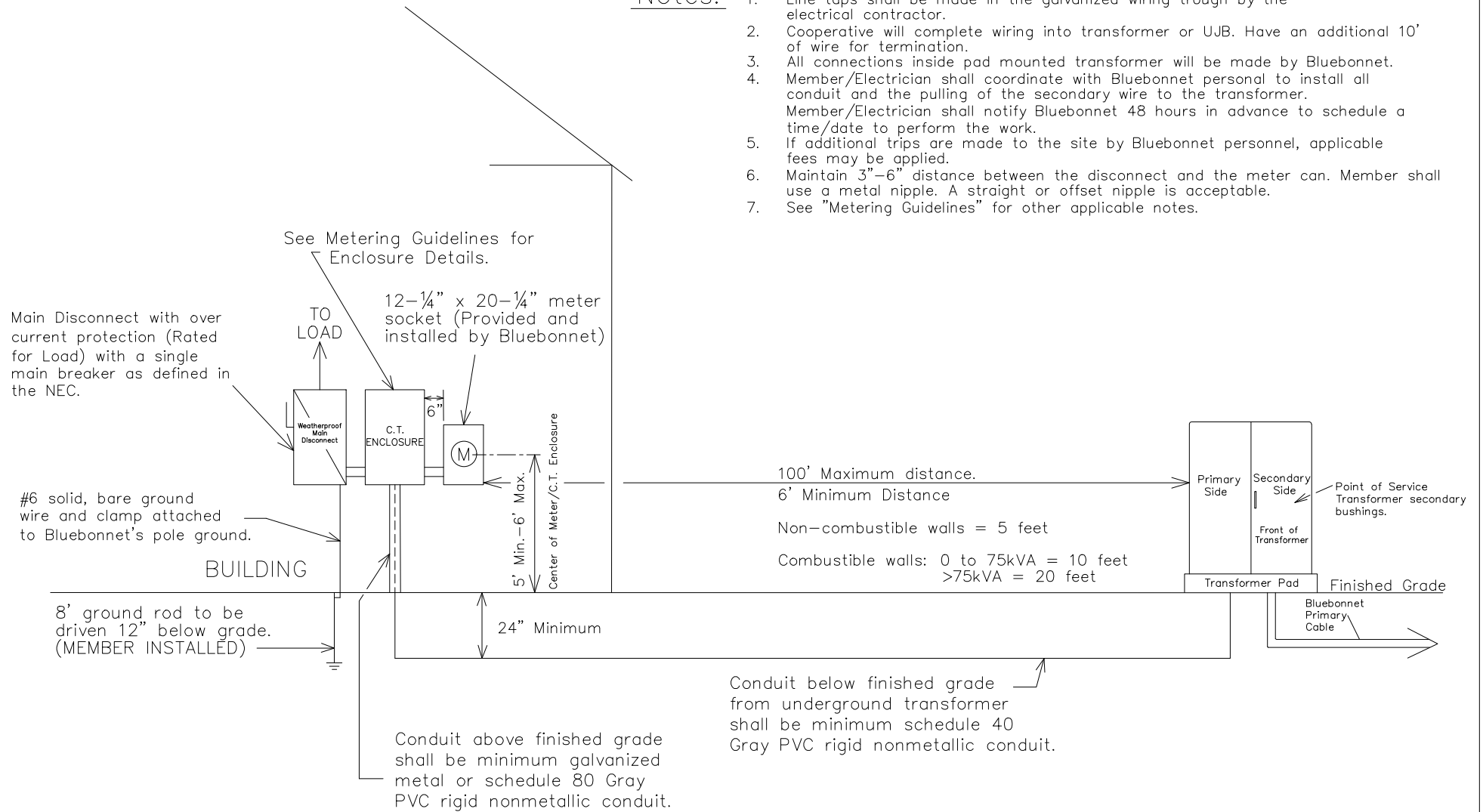

3 Phase >200 AMP SERVICE WITH CT  
METERING ON BUILDING OR RACK

11-20-2019	Added Solid Copper Note.
04-19-2021	Removed Single Phase from the CT Enclosure Note.
11-04-2021	Added Main Breaker Note.

Drawn By :  
RG

Scale :  
NONE

Checked By :  
MS COMMITTEE

Date :  
11-04-2021

Approved By :  
MS COMMITTEE

MS-204B3

Single Phase Transformer Layout

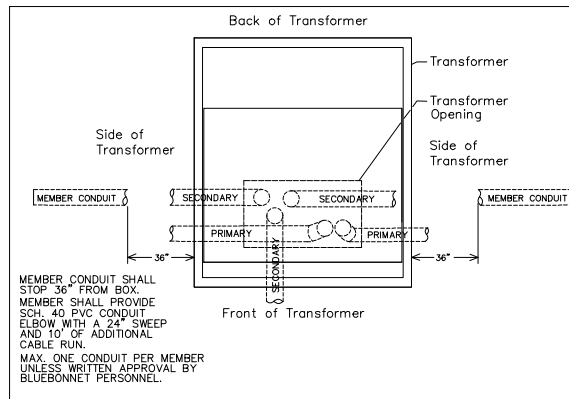

No more than four 60-200 Amp meter sockets and weatherproof main disconnects. No more than one disconnect per enclosure.

Notes:

1. Line taps shall be made in the galvanized trough by the electrical contractor.
2. More than (6) main disconnects require a properly sized main disconnect ahead of the galvanized trough.
3. Bluebonnet will complete wiring into transformer. Have 10' additional amount of wire for termination.
4. THREE PHASE APPLICATIONS ONLY DESCRIPTION: 200amp, 7 terminal, 3-phase, 4-wire will require a lever by-pass meeting ANSI C12.7, UL 414, and NEMA 3R. Meter cans are available for purchase through Techline or any other electrical supplier provided it meets all Bluebonnet Electric Cooperative specifications.
5. Member/Electrician shall coordinate with Bluebonnet personal to install all conduit and the pulling of the secondary wire to the transformer. Member/Electrician shall notify Bluebonnet 48 hours in advance to schedule a time/date to perform the work.
6. If additional trips are made to the site by Bluebonnet personnel, applicable fees maybe applied.
7. See "Metering Guidelines" for other applicable notes.

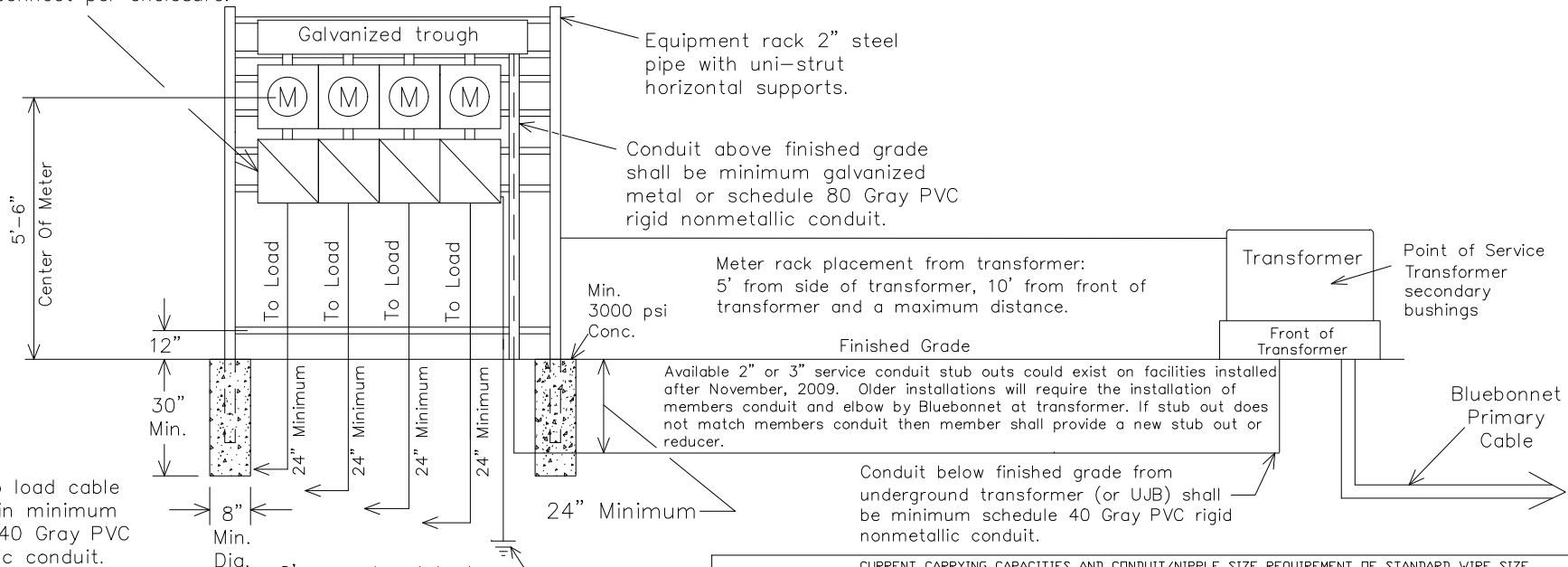

Service to load cable enclosed in minimum schedule 40 Gray PVC nonmetallic conduit.

8' ground rod to be driven 12" below grade. (Member Installed)

CURRENT CARRYING CAPACITIES AND CONDUIT/NIPPLE SIZE REQUIREMENT OF STANDARD WIRE SIZE.  
(RHH, RHW, THW, THWN, THHN, AND XHHW)  
REFER TO NEC FOR OTHER CALCULATIONS.

WIRE SIZE	COPPER CONDUCTOR		WIRE SIZE	ALUMINUM CONDUCTOR	
	BREAKER SIZE	CONDUIT/NIPPLE SIZE		BREAKER SIZE	CONDUIT/NIPPLE SIZE
#6	60 AMP	1 1/4" CONDUIT	#4	60 AMP	1 1/4" CONDUIT
#4	100 AMP	1 1/2" CONDUIT	#2	100 AMP	1 1/2" CONDUIT
#2	125 AMP	1 3/4" CONDUIT	#1/0	125 AMP	1 3/4" CONDUIT
#1	150 AMP	2" CONDUIT	#2/0	150 AMP	1 3/2" CONDUIT
#2/0	200 AMP	2" CONDUIT	#4/0		2" CONDUIT



1Ø OR 3Ø, 60-200 AMP UNDERGROUND GANG MOUNTED METERS ON RACK OR BUILDING NOT TO EXCEED A TOTAL OF 800 AMPS.

DATE	REVISIONS
12-07-2017	ADDED WIRE SIZING CHART.
12-07-2017	ADDED MAIN BREAKER NOTE

Drawn By :  
RG  
Scale :  
NONE

Checked By :  
MS COMMITTEE  
Date :  
11-04-2021

Approved By :  
MS COMMITTEE  
MS-205

CURRENT CARRYING CAPACITIES AND CONDUIT SIZE REQUIREMENT OF STANDARD WIRE SIZE (RH,RHH,RHW,THW,AND XHHW)					
COPPER CONDUCTOR			ALUMINUM CONDUCTOR		
WIRE SIZE	BREAKER SIZE	CONDUIT SIZE	WIRE SIZE	BREAKER SIZE	CONDUIT SIZE
#6	60 AMP	1¼" CONDUIT	#4	60 AMP	1¼" CONDUIT
#4	100 AMP	1¼" CONDUIT	#2	100 AMP	1¼" CONDUIT
#2	125 AMP	1½" CONDUIT	#1/0	125 AMP	1½" CONDUIT
#1	150 AMP	2" CONDUIT	#2/0	150 AMP	2" CONDUIT
#2/0	200 AMP	2" CONDUIT	#4/0	200 AMP	2" CONDUIT

- Notes:
1. Cooperative will complete wiring between pedestal and transformer or UJB. Have sufficient amount of wire for termination.
  2. Main disconnect supplied with pedestal. Repair or replacement of main disconnect after initial installation will be responsibility of member.
  3. Meter pedestal must remain unenclosed and accessible by Bluebonnet personnel at all times.
  4. Member/Developer – Do not stub out secondary conduit to house until pedestal is installed.
  5. See "Metering Guidelines" for other applicable notes.

These meter pedestals are available for purchase through Techline.

200A URD Meter pedestal  
If purchased from TechLine,  
installed by Bluebonnet  
Contractor during job  
construction.

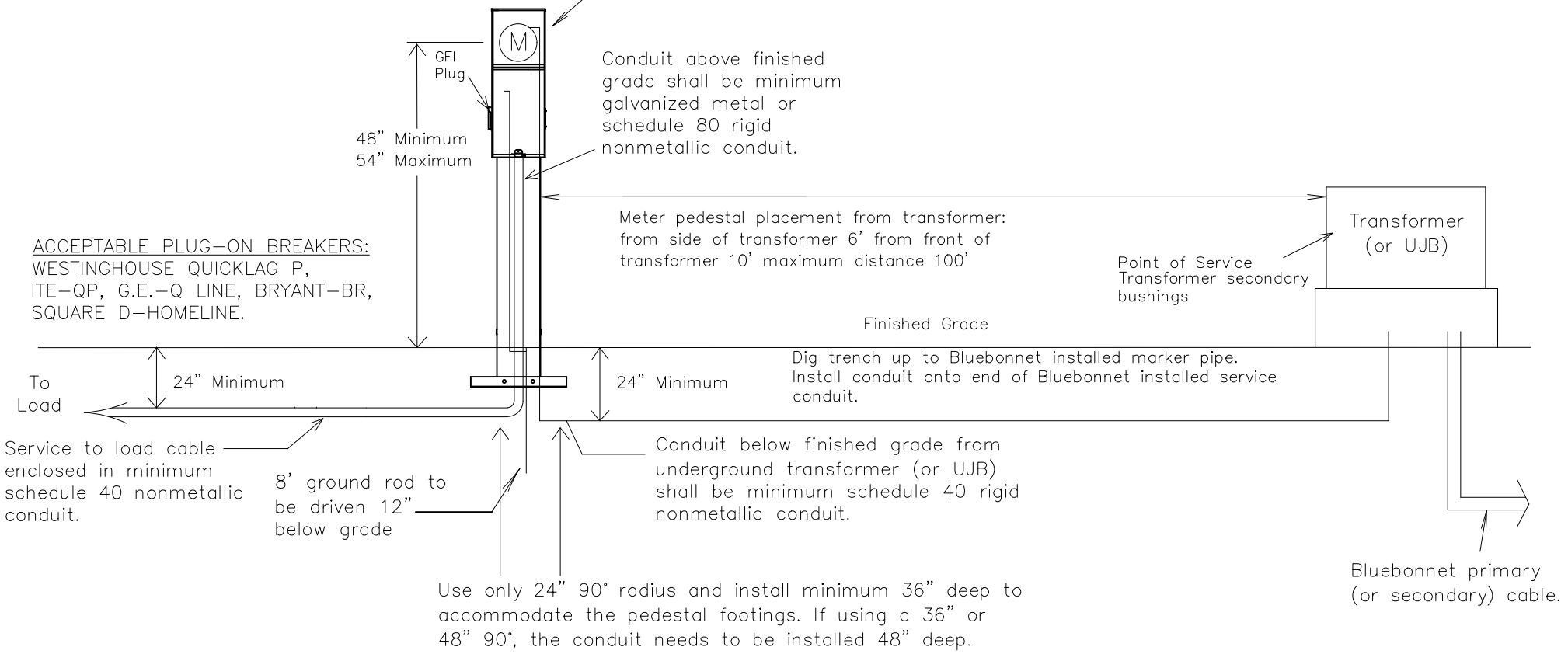

ACCEPTABLE PLUG-ON BREAKERS:  
WESTINGHOUSE QUICKLAG P,  
ITE-QP, G.E.-Q LINE, BRYANT-BR,  
SQUARE D-HOMELINE.



1Ø, 60-200 AMP URD SERVICE ON URD METER PEDESTAL	
DATE	REVISIONS

Drawn By :  
JB  
Scale :  
NONE

Checked By :  
MS COMMITTEE  
Date :  
1-21-22

Approved By :  
TE  
MS-206

Notes:

1. Covers on circuit breaker compartments must be removable without disturbing meters.
2. Meter socket components must be readily accessible and removable for maintenance.
3. Wire sized to total disconnect sizes.
4. Bluebonnet will complete wiring into transformer.
5. If a main disconnect module is used, its cover must have provisions for a standard Bluebonnet padlock.
6. Member/Electrician shall coordinate with Bluebonnet personnel to install all conduit and the pulling of the secondary wire to the transformer. Member/Electrician shall notify Bluebonnet 48 hours in advance to schedule a time/date to perform the work. If additional trips are made to the site by Bluebonnet personnel, applicable fees maybe applied.
7. #6 Solid, Bare ground copper wire and clamp attached to Bluebonnet's pole ground.
8. No more than one disconnect per enclosure.
9. Max wire size for single-phase underground transformers to be 350 kcmil
10. Limit number of conductors to 4 per phase.
11. See "Metering Guidelines" for other applicable notes.

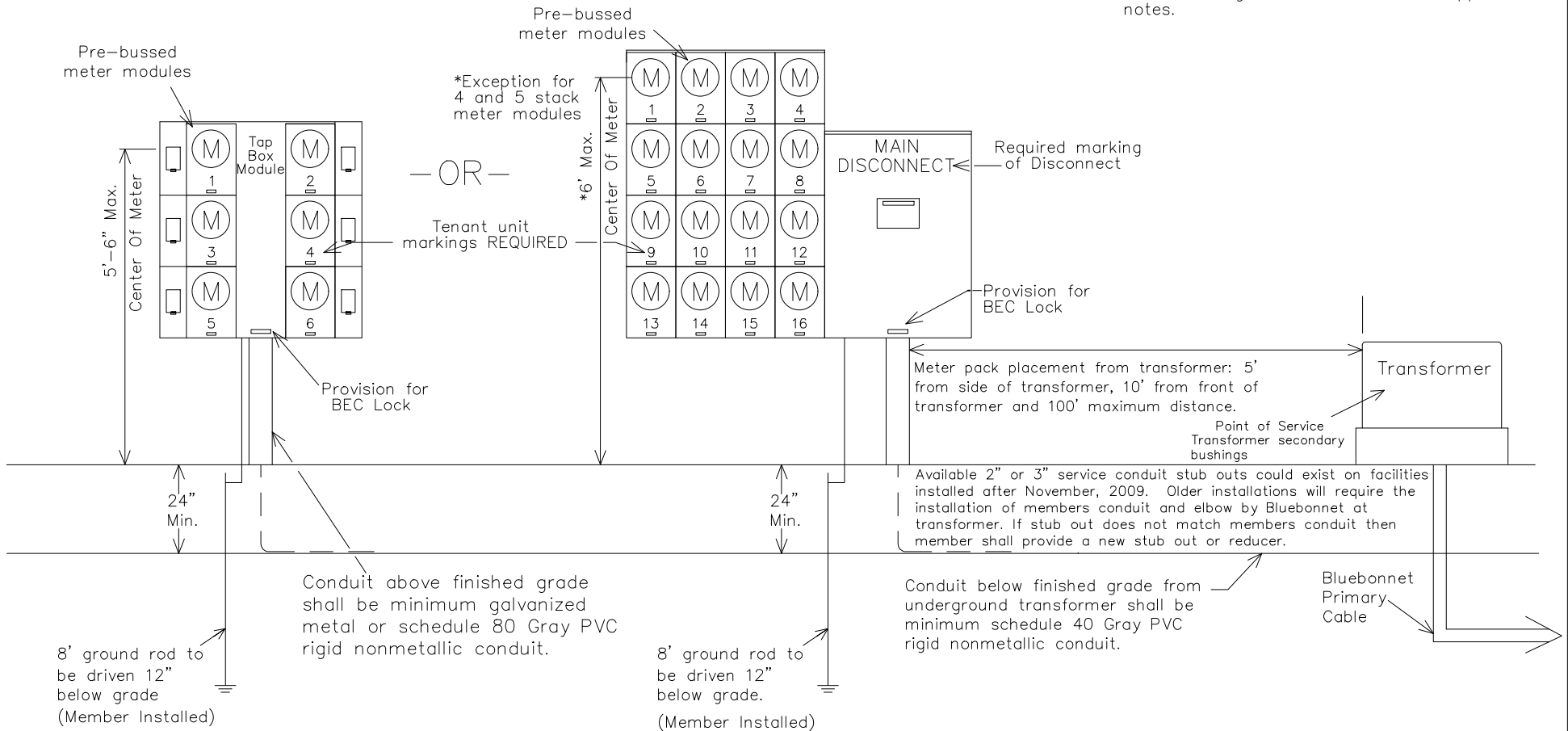

1Ø 60-200 AMP UNDERGROUND MULTI-PACK METERS ON BUILDING		Drawn By : BS	Checked By : MS COMMITTEE	Approved By : MS COMMITTEE
DATE	REVISIONS	Scale : NONE	Date : 12-30-2025	MS-207
11-20-19	Added Solid Copper Note.			
11-04-21	Added Main Breaker Note.			

Notes:

1. Covers on circuit breaker compartments must be removable without disturbing meters.
2. Meter socket components must be readily accessible and removable for maintenance.
3. Wire sized to total disconnect sizes.
4. Bluebonnet will complete wiring into transformer. Have sufficient amount of wire for termination.
5. If a main disconnect module is used, its cover must have provisions for a standard Bluebonnet padlock.
6. Member/Electrician shall coordinate with Bluebonnet personal to install all conduit and the pulling of the secondary wire to the transformer. Member/Electrician shall notify Bluebonnet 48 hours in advance to schedule a time/date to perform the work.
7. If additional trips are made to the site by Bluebonnet personnel, applicable fees maybe applied.
8. #6 solid, bare ground copper wire and clamp attached to Bluebonnet's pole ground.
9. No more than one disconnect per enclosure.
10. See "Metering Guidelines" for other applicable notes.

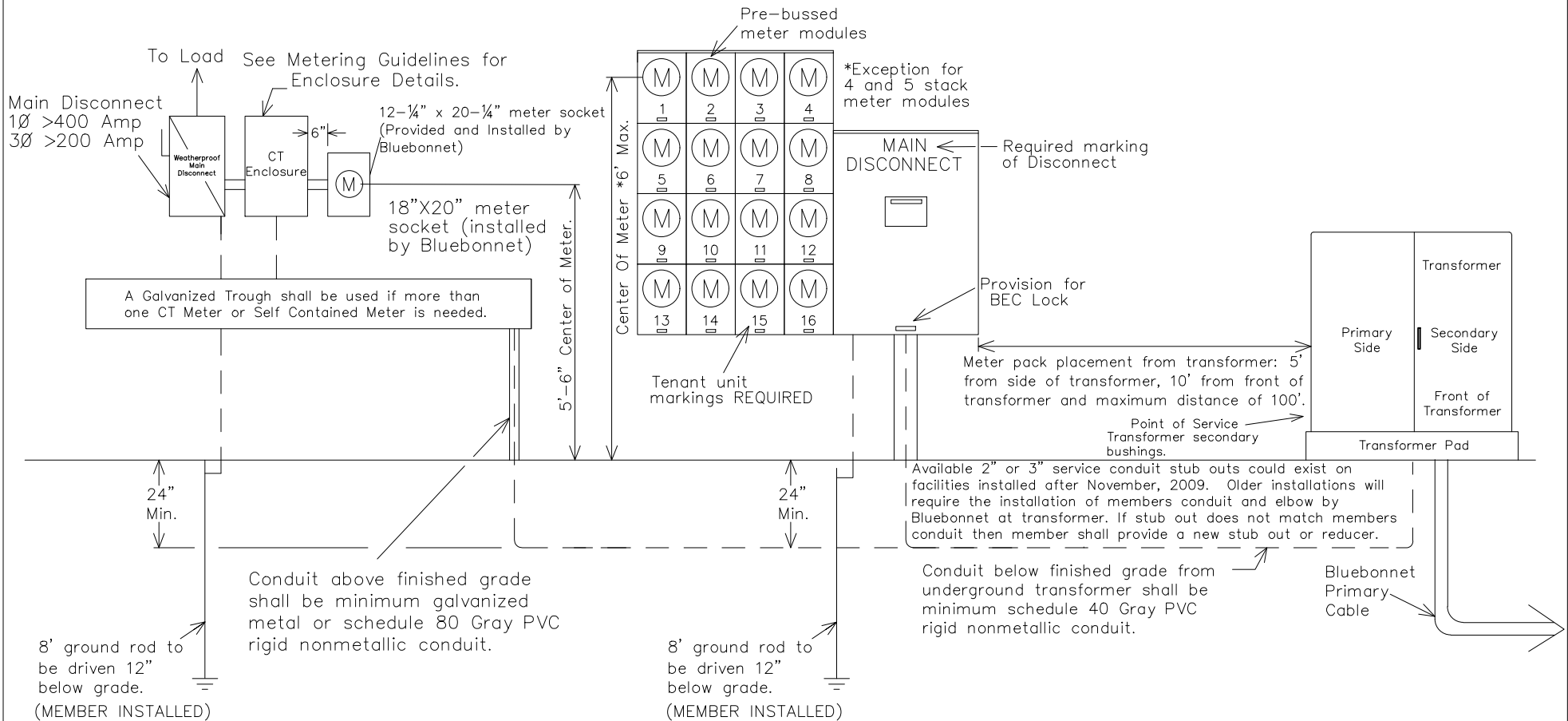

3Ø 60-200 AMP UNDERGROUND MULTI-PACK METERS & 3Ø < or >200 AMP ON BUILDING	
DATE	REVISIONS
11-20-2019	Added Solid Copper Note.
11-04-2021	Added Main Breaker Note.

Drawn By :	RG
Scale :	NONE

Checked By :	MS COMMITTEE
Date :	11-04-2021

Approved By :	MS COMMITTEE
	MS-207B

Notes:

1. A Bond wire shall be used, see NEC Table 250.66 for Bond Wire sizing.
2. Height of meter loop riser will be determined by BEC.
3. Grounded leg shall be identified and shall be landed in the center of the meter can.
4. See "Metering Guidelines" for all other applicable notes.

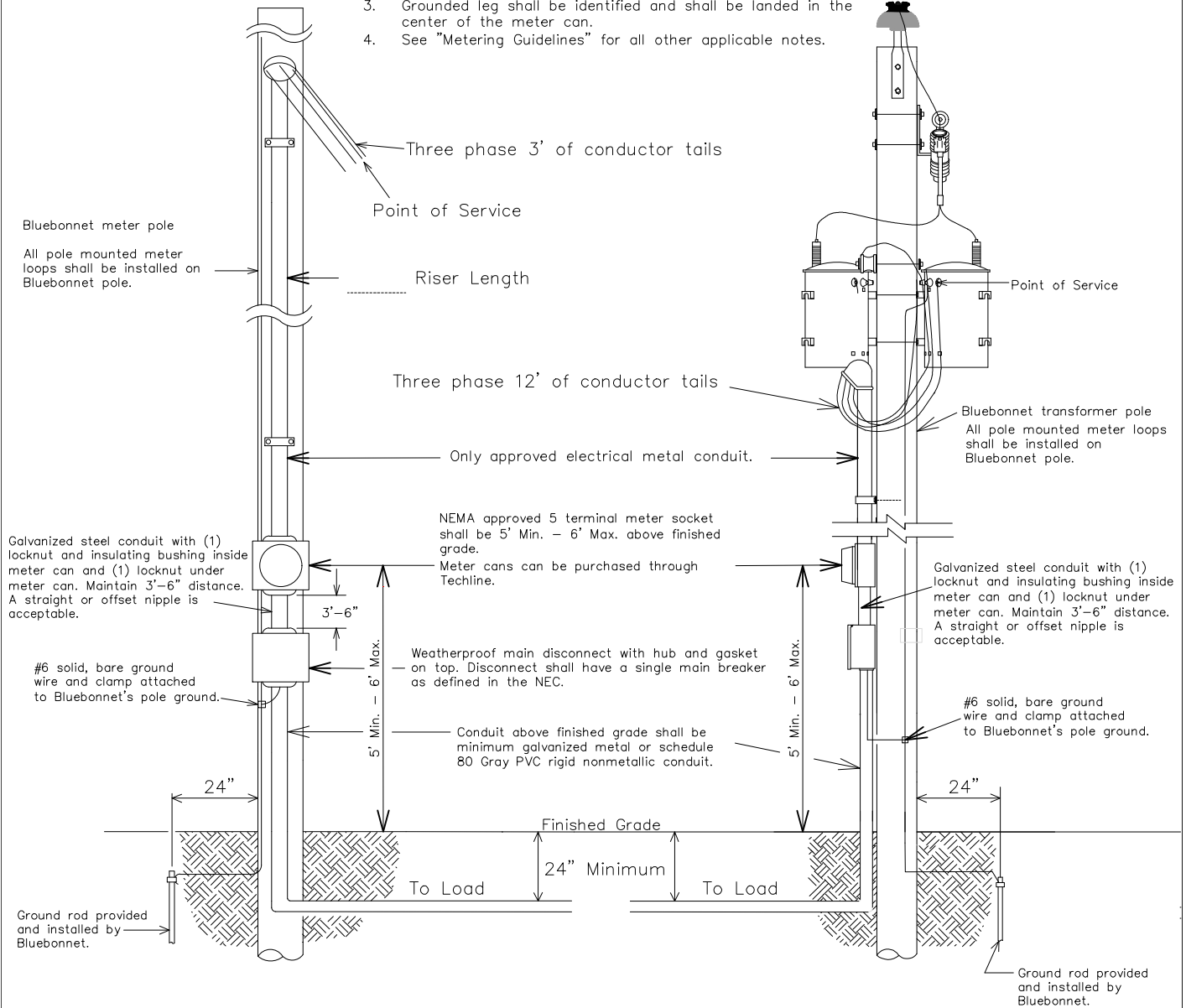

CURRENT CARRYING CAPACITIES AND CONDUIT SIZE REQUIREMENT OF STANDARD WIRE SIZE—(RHH, RHW, THW, THWN, THHN, AND XHHW REFER TO NEC FOR OTHER CALCULATIONS.

WIRE SIZE	COPPER CONDUCTOR		WIRE SIZE	ALUMINUM CONDUCTOR	
	BREAKER SIZE	CONDUIT SIZE		BREAKER SIZE	CONDUIT SIZE
#6	60 AMP	1¼" CONDUIT	#4	60 AMP	1¼" CONDUIT
#4	100 AMP	1¼" CONDUIT	#2	100 AMP	1¼" CONDUIT
#2	125 AMP	1½" CONDUIT	#1/0	125 AMP	1½" CONDUIT
#1	150 AMP	2" CONDUIT	#2/0	150 AMP	2" CONDUIT
#2/0	200 AMP	2" CONDUIT	#4/0	200 AMP	2" CONDUIT

3Ø, STRAIGHT 480 VOLT  
3W CORNER GROUND DELTA  
60-200 AMP



DATE	REVISIONS	Drawn By :	Checked By :	Approved By :
12-07-2017	Changed the wording on Note # 6.	RG	MS COMMITTEE	MS COMMITTEE
11-04-2021	Added Main Breaker Note	Scale :	Date:	
		NONE	11-04-2021	MS-301A

Notes:

1. A Bond wire shall be used, see NEC Table 250.66 for Bond Wire sizing.
2. Height of meter loop riser will be determined by BEC.
3. High leg on a Delta System shall be landed on the right side of the meter can and tapped with orange tap.
4. See "Metering Guidelines" for all other applicable notes.

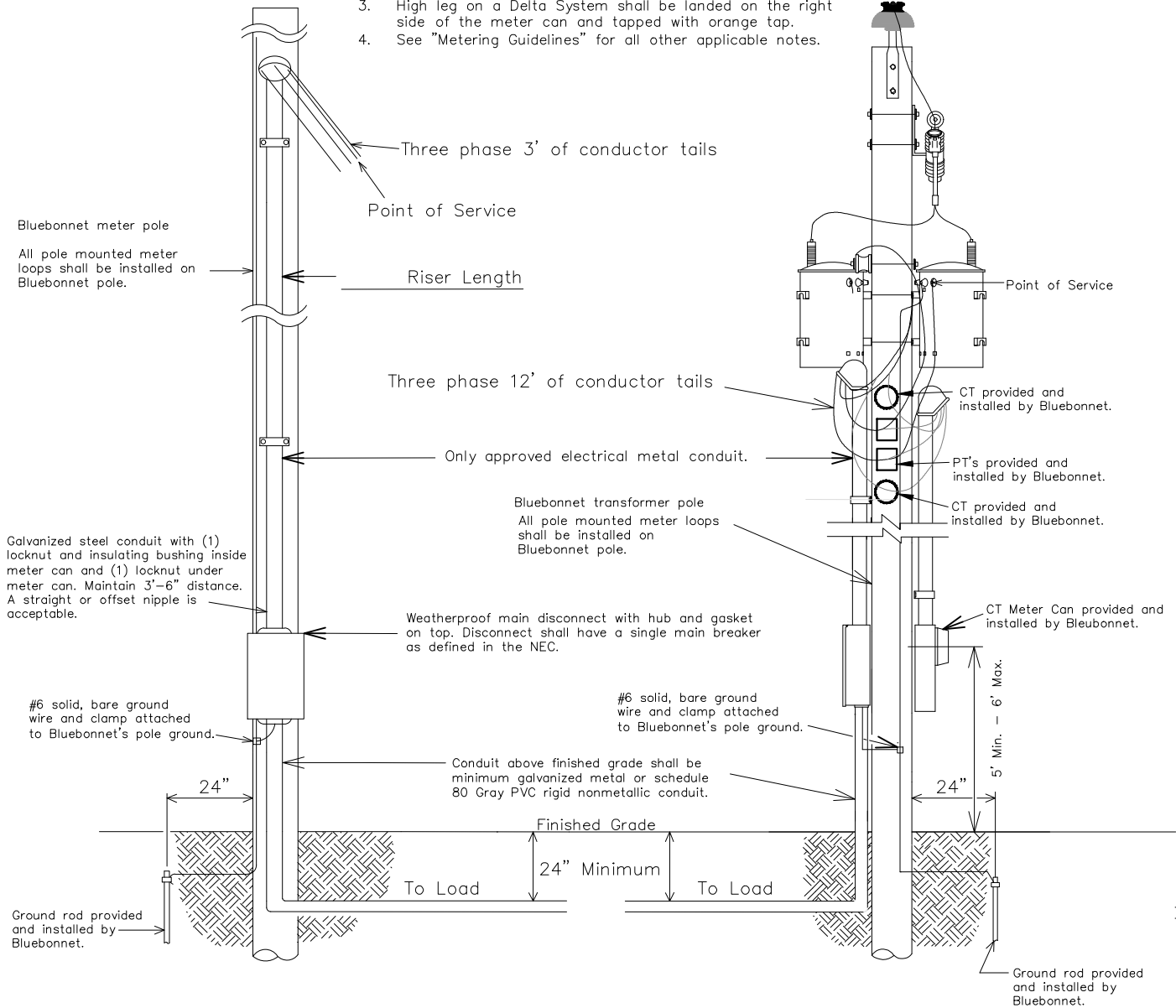

CURRENT CARRYING CAPACITIES AND CONDUIT SIZE REQUIREMENT OF STANDARD WIRE SIZE--(RHH, RHW, THW, THWN, THHN, AND XHHW REFER TO NEC FOR OTHER CALCULATIONS.

WIRE SIZE	COPPER CONDUCTOR		WIRE SIZE	ALUMINUM CONDUCTOR	
	BREAKER SIZE	CONDUIT SIZE		BREAKER SIZE	CONDUIT SIZE
#6	60 AMP	1¼" CONDUIT	#4	60 AMP	1¼" CONDUIT
#4	100 AMP	1¼" CONDUIT	#2	100 AMP	1¼" CONDUIT
#2	125 AMP	1½" CONDUIT	#1/0	125 AMP	1½" CONDUIT
#1	150 AMP	2" CONDUIT	#2/0	150 AMP	2" CONDUIT
#2/0	200 AMP	2" CONDUIT	#4/0	200 AMP	2" CONDUIT

3 PHASE, STRAIGHT 480 VOLT 3W CORNER GROUND DELTA >200 AMP



DATE	REVISIONS		Drawn By :	Checked By :	Approved By :
11-04-21	Added Main Breaker Note		RG	MS COMMITTEE	MS COMMITTEE
-	-		Scale :	Date:	MS-301B
			NONE	11-04-2021	

Notes:

- Line taps shall be made in the galvanized wire trough by the electrical contractor.
- When more than (1) disconnect is used, a galvanized rough system shall be installed.
- Two (2) disconnects could be substituted with (1) disconnect. All disconnects shall have over current protection installed.
- No more than two (2) risers or two (2) conductors per phase shall be allowed.
- Maintain 3"-6" distance between the disconnect and the meter can. Member shall use a metal nipple. A straight or offset nipple is acceptable.
- #6 solid, bare ground copper wire and clamp attached to Bluebonnet's pole ground.
- High leg on a Delta System shall be landed on the right side of the meter can and taped with orange tape.
- See "Metering Guidelines" for all other applicable notes.

Ⓐ Transformer Pole Riser Length:  
 35' Pole = 20' Riser  
 40' Pole = 24' Riser

Ⓑ Service Pole Riser Length:  
 30' Pole = 20' Riser  
 35' Pole = 24' Riser

Ⓒ Member's Conduit  
 Member's conduit shall be installed 8"-12" from pole

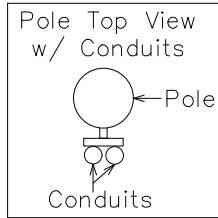

Only 2", 3", or 4" approved electrical metal conduit is allowed. Risers will not exceed 2 risers per pole. Member will provide 12' of conductor tails from top of weatherhead. Bluebonnet to supply stand-offs. (Bluebonnet to mount risers to pole).

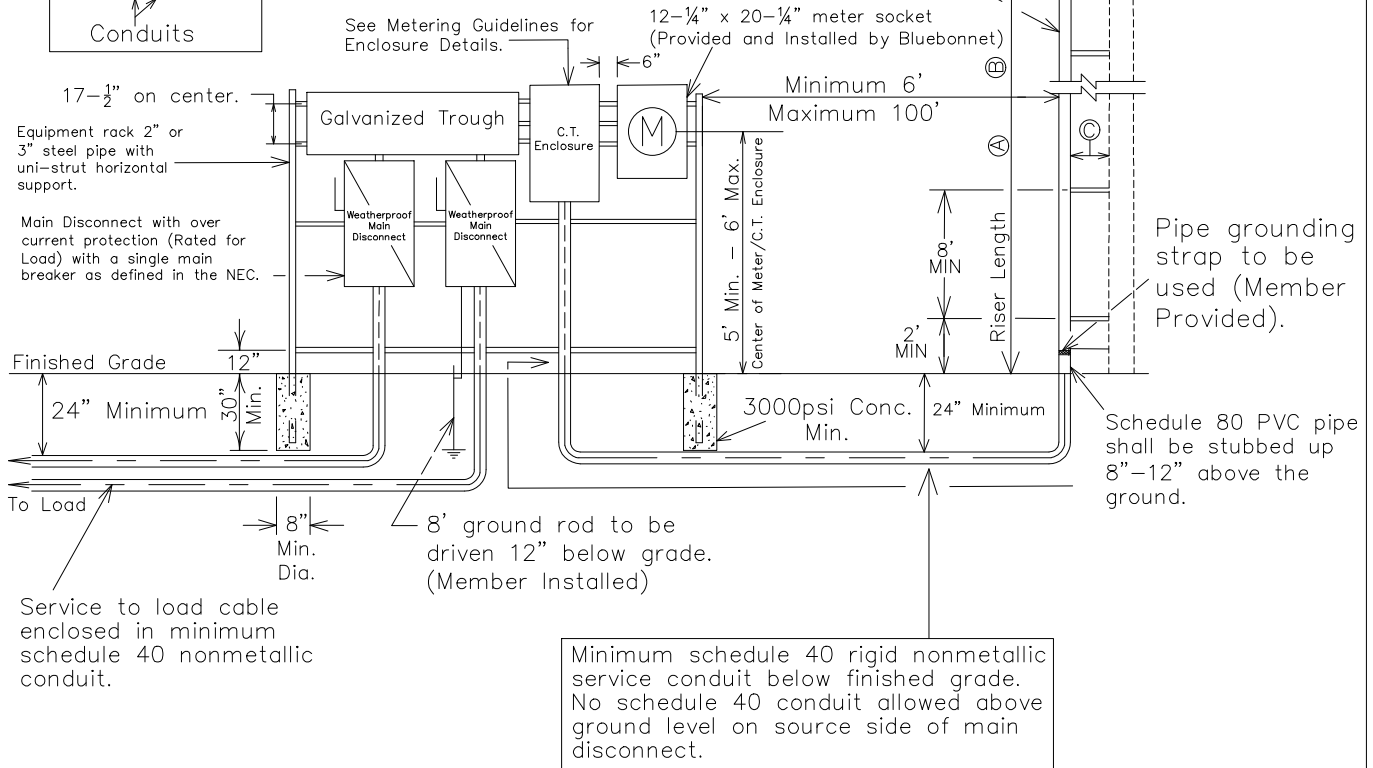
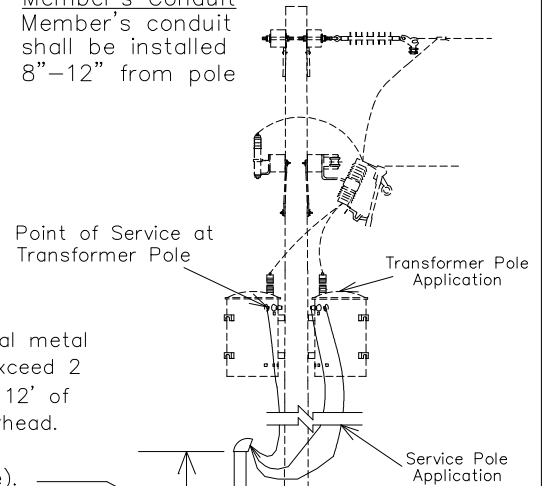

3PH, STRAIGHT 480 VOLT 3W CORNER GROUND  
 DELTA >200 AMP ON RACK OR BUILDING



Drawn By : DK	Checked By : CV	Approved By : STANDARDS
Scale : NONE	DATE: Jun. 27, 2023	MS-301C

Notes:

- All temporary wiring shall meet national electrical code standards.
- All outlets attached to meter loop shall have ground-fault circuit interrupter protection.
- For all URD jobs, electricians shall call TEXAS811 for locates before digging to Bluebonnet equipment. No private utilities will be located.
- Service wires shall be brought to the top side of the meter base.
- Bluebonnet does inspect temporary meter loops and a fee shall be charged per trip for wiring inspection. Bluebonnet will refuse service if hazardous conditions exist and/or if connections do not meet specifications.
- Bluebonnet will complete wiring into transformer or UJB. Member shall have sufficient amount of wire for termination.
- All connections inside pad mounted transformer and UJB's will be made by Bluebonnet.
- Temporary Meter Loop Services are good for up to 24 months of service or less.
- The main electrical disconnect for each electrical service shall be installed on the exterior of the building in a location approved by Bluebonnet Electric Cooperative.

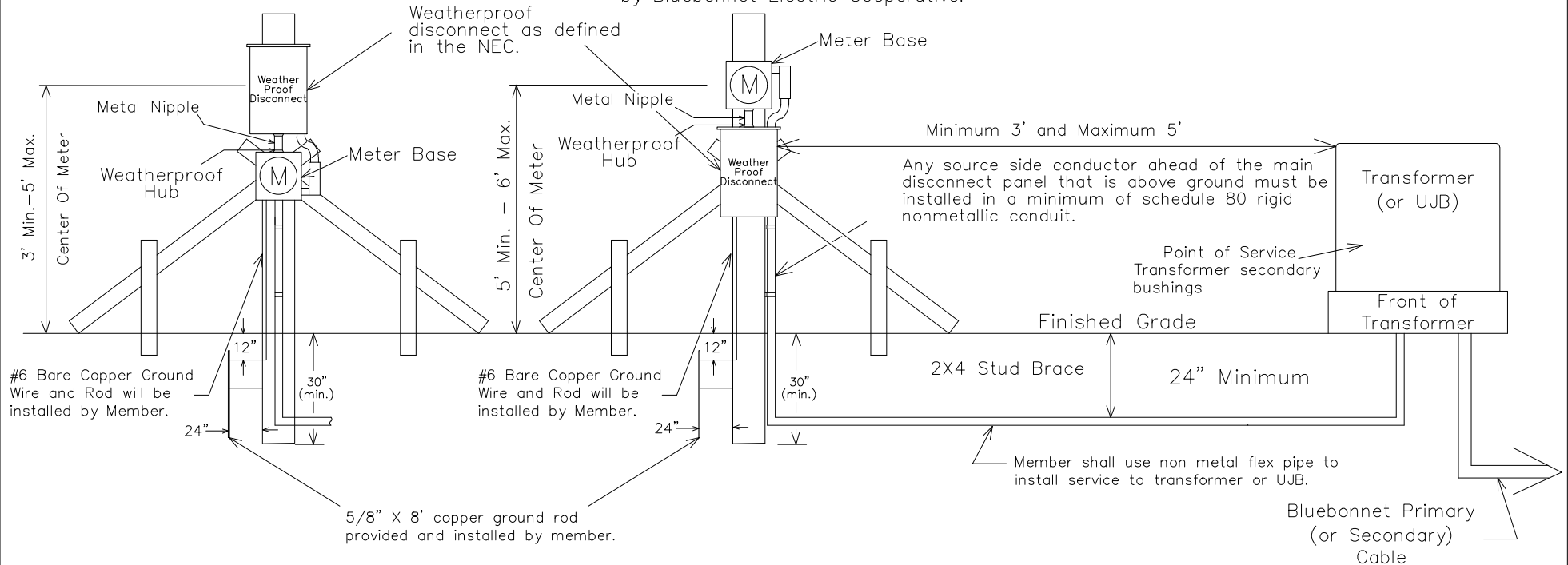

CURRENT CARRYING CAPACITIES AND CONDUIT/NIPPLE SIZE REQUIREMENT OF STANDARD WIRE SIZE  
(RHH, RHW, THW, THWN, THHN, AND XHHW)  
REFER TO NEC FOR OTHER CALCULATIONS.

COPPER CONDUCTOR			ALUMINUM CONDUCTOR		
WIRE SIZE	BREAKER SIZE	CONDUIT SIZE	WIRE SIZE	BREAKER SIZE	CONDUIT SIZE
#6	60 AMP	1 1/4" CONDUIT	#4	60 AMP	1 1/4" CONDUIT
#4	100 AMP	1 1/4" CONDUIT	#2	100 AMP	1 1/4" CONDUIT
#2	125 AMP	1 1/2" CONDUIT	#1/0	125 AMP	1 1/2" CONDUIT
#1	150 AMP	2" CONDUIT	#2/0	150 AMP	2" CONDUIT
#2/0	200 AMP	2" CONDUIT	#4/0	200 AMP	2" CONDUIT



TEMPORARY METER LOOP FOR UNDERGROUND SERVICE		Drawn By : RG	Checked By : MS COMMITTEE	Approved By : MS COMMITTEE
DATE	REVISIONS	Scale : NONE	DATE: 11-04-2021	MS-302
03-29-2018	ADDED ADDITIONAL METER SETUP.			
11-04-2021	ADDED MAIN BREAKER NOTE			

Notes:

1. All pole mounted meter loops shall be mounted to Bluebonnet poles.
2. All secondary connections made by Bluebonnet.
3. All outlets attached to meter loop shall have ground-fault circuit interrupter protection.
4. Temporary Meter Loop Services are good for 24 months of service or less
5. For your safety, only Bluebonnet personnel are authorized to install meter loops or other BEC equipment on a Bluebonnet pole. Members shall have loop assembled and available for installation by Bluebonnet.

Bluebonnet does inspect temporary meter loops and a fee shall be charged per trip for wiring inspections. Bluebonnet will deny service if hazardous conditions do not meet specifications.

FOR THREE PHASE APPLICATIONS  
DESCRIPTION:

200amp, 7 terminal, 3-phase, 4-wire will require a lever by-pass meeting ANSI C12.7, UL 414, an NEMA 3R. Meter cans are available for purchase through Techline or any other electrical supplier provided it meets all Bluebonnet Electric Cooperative specifications. Techline (512-332-2978)

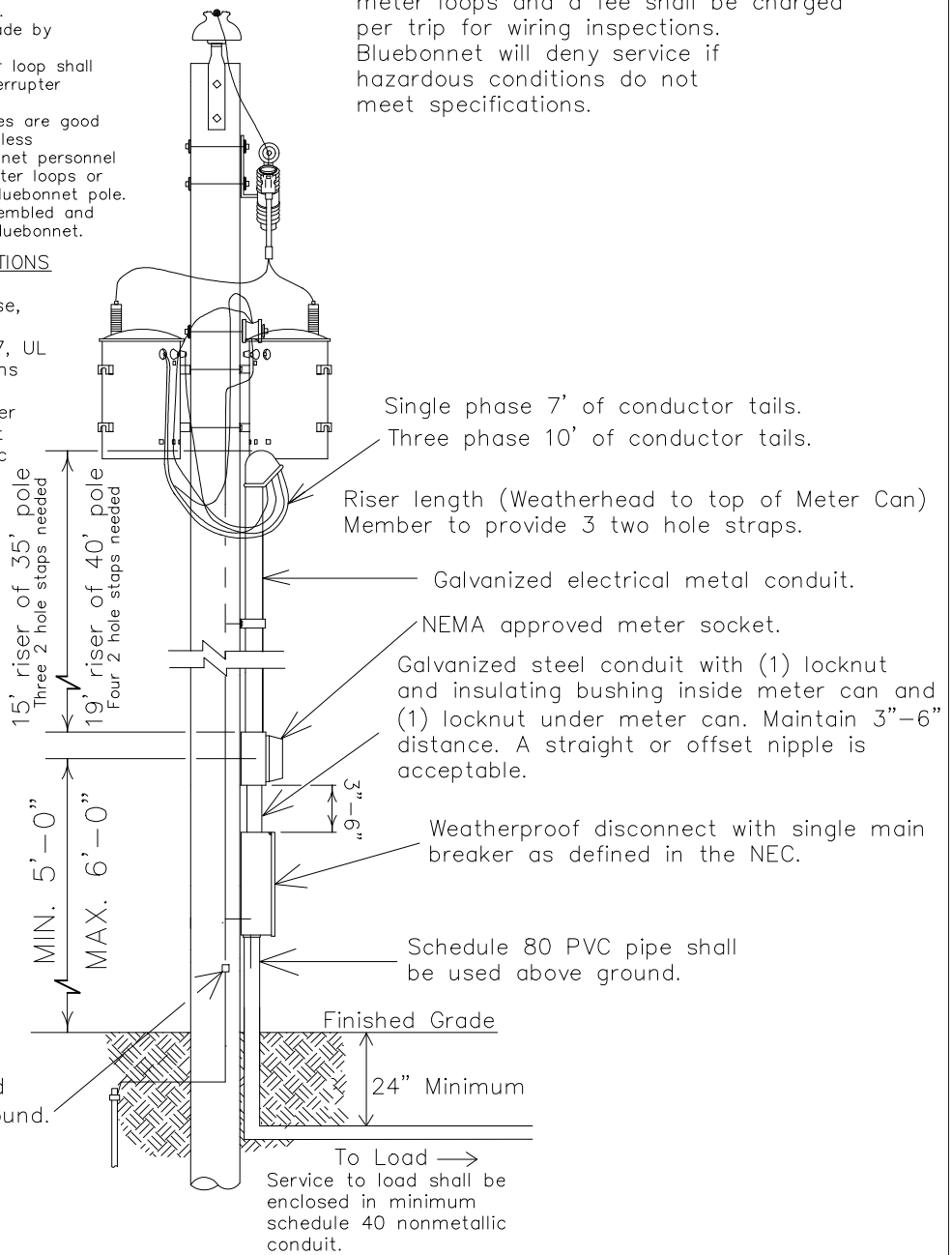

CURRENT CARRYING CAPACITIES AND CONDUIT SIZE REQUIREMENT OF STANDARD WIRE  
SIZE - (RHH, RHW, THW, THWN, THHN, AND XHHW)  
REFER TO NEC FOR OTHER CALCULATIONS.

COPPER CONDUCTOR

Wire Size	Breaker Size	Conduit Size
#6	60 Amp	1 1/4" Conduit
#4	100 Amp	1 1/4" Conduit
#2	125 Amp	1 1/2" Conduit
#1	150 Amp	2" Conduit
#2/0	200 Amp	2" Conduit

ALUMINUM CONDUCTOR

Wire Size	Breaker Size	Conduit Size
#4	60 Amp	1 1/4" Conduit
#2	100 Amp	1 1/4" Conduit
#1/0	125 Amp	1 1/2" Conduit
#2/0	150 Amp	2" Conduit
#4/0	200 Amp	2" Conduit

1Ø OR 3Ø 60-200 AMP TEMPORARY METER LOOP FOR TRANSFORMER AND SERVICE POLES



Drawn By : SF	Checked By : MS COMMITTEE	Approved By : MS COMMITTEE
Scale : NONE	DATE: 8-26-2025	MS-303

DATE	REVISIONS
8-26-25	Changed riser requirements to be full sized
11-04-21	Added main breaker note